

"The wise man looks into space,  
and knows there is no limit to dimension."  
said Chuangtzu.  
The wise Radioist bridges the greatest  
distances with a

# Grebe Receiver.

*Doctor Mu.*



A LONG RECORD of unequalled performance has won for the Grebe Receiver the unqualified endorsement of all good dealers.

"Musings of Doctor Mu" — the story of the development of the Perfect Receiver, free upon request.

A. H. GREBE & CO.  
INCORPORATED  
RICHMOND HILL, N. Y.



Licensed under  
Armstrong U. S.  
Pat. No. 1113149





#### PUTTING THEIR HEADQUARTERS STATION ON THE MAP

Boy Scouts of Troop 1, Roslyn, Long Island, using a loop receiver to determine the position of their transmitting station at troop headquarters. Bearings taken from two or more locations are plotted on the map; and the point where these direction lines meet indicates the position of the transmitting station. Left to right: Scouts Denton, Fontaine, Miller and Malmros

# RADIO BROADCAST

Vol. 2 No. 4



February, 1923

## The March of Radio

### "DRY-CELL TUBES" FOR RECEIVING

**T**HE vacuum-tube is so far superior for distance work and selective tuning to the crystal detector that no comparison can be drawn as to their relative merits. The crystal set makes available in the telephone receivers a certain small part of the radio power picked up by the antenna, perhaps a fraction of one thousandth of a watt. The amount of power which the antenna can pick up decreases rapidly as the distance from the transmitting station increases, and this fact generally limits the use of the crystal detector to points fifty miles or less from the broadcasting station.

The vacuum-tube receiver works on an entirely different principle; in the B battery is stored energy millions of times greater than that picked up by the antenna and the tube acts as a trigger to this local energy supply, changing the rate of energy flow from the B battery in accordance with the potential of the grid which itself is excited by the minute energy picked up by the antenna. Thus a tube set may make audible a signal of perhaps one millionth the strength necessary for audibility with a crystal set. Why then is it that the crystal set has any chance at all in the competition?

To this question there are several possible answers, the principal one being that of cost, both the first cost and the maintenance. A fair crystal set can be purchased for \$25 and no auxiliary apparatus is required, whereas a

corresponding tube set would cost perhaps \$100 itself and in addition there must be purchased a storage battery and plate-circuit battery before it can function. The storage battery for the filament circuit is expensive, messy and inconvenient to care for, and is a continual source of expense because of the re-charging required. The B battery will last only about one year before it becomes noisy and it must then be renewed. Tubes burn out occasionally and many people find it very difficult to keep supplied with them.

One of the great advances in tube manufacture has recently been made available with the appearance on the market of the Westinghouse "dry-cell tube." In this tube the filament is coated in such a way that the emission of electrons occurs at the required rate at a low temperature: in fact, the filament has no visible glow in daylight, requires only one quarter of an ampere to heat, and has a low enough resistance to allow the voltage of one dry cell to force the required current through it. The power used in this filament is therefore about 0.3 watt, whereas the tungsten filament tubes ordinarily used require about 7 watts for the filament. The new tube therefore represents a decrease in the required filament power in the ratio of twenty to one. One six-inch dry cell is sufficient to excite the filament for from fifty to one hundred hours, depending upon how continuously the tube is used. The first cost and the recharging cost of a

storage battery are done away with and the single-tube receiving set, having a receiving range of a hundred miles or more, need be but little more expensive than the better crystal sets. From what tests we have been able to make, these new tubes should function about as well as the older type, both as detectors and amplifiers.

While in conversation with one of the research workers engaged in tube manufacture and development, we were told recently that a quarter of an ampere for the filament is much more than necessary—that one twentieth of an ampere is plenty for the filament of a satisfactory receiving tube! So events in the vacuum-tube field are crowding one another very rapidly. It is really very difficult for the manufacturing company to decide when and how to start a new tube in production, for no sooner are the dies, jigs, and processes perfected than the research man reports a new development which indicates that previous types should be discarded!

It is an expensive process for the manufacturer to cease production on one type and begin on another. Of course, the buying public must eventually pay the cost, and it is not to be expected therefore that the price of the new tubes will be materially lower than that of the present ones, until enough of them have been sold to pay for the development costs. Judging from the present rate of progress, the new tube will be discarded for a superior one before that point is reached.

Soon after the foregoing was written, Dr. A. W. Hull, of the research laboratory of the General Electric Company, justified the ideas there set forth by reading before the Institute of Radio Engineers a paper on a new tube he had developed during the past few months. Some years ago J. H. Morecroft pointed out several of the advantages to be gained by having a uni-potential cathode in a vacuum tube and actually constructed such a tube by putting the hot filament inside a tungsten thimble. The filament heated the thimble by radiation and this hot thimble served as the source of electrons. As no current was flowing along the thimble the resistance drop in the filament was zero and certain defects in the characteristics of the ordinary hot filament tube were eliminated. Dr. Hull has succeeded in developing a small receiving tube on this

principle, permitting the use of alternating current to heat the filament of the detecting tube. The technical value of this new departure in tube manufacture may not seem evident at once, but when it is seen that such a tube makes it possible to obtain all the power required, both for filament and plate circuits, from the ordinary house wiring with its alternating current power supply, some appreciation of the rôle it may play in receiving sets will be gained. A receiver, amplifier, and loud speaker, all operated from an ordinary lamp socket—that indeed sounds attractive. There is apparently nothing to prevent such a combination except the policy of the manufacturer in pushing the development of these new uni-potential cathode vacuum tubes.

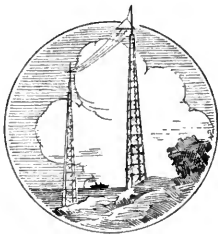

### The Standing of the Amateur

RUMORS are emanating from Washington which indicate that the legal status of the amateur is being seriously threatened, and that his activities may be much curtailed. It would be a serious mistake, we believe, to hamper unnecessarily the activities of these enthusiasts who have done so much in short-wave telegraphy during the last twenty years. The present radio public must of course be properly served, but the amateur, who studied and worked at the game long before the public was interested, has contributed a great deal, directly as well as indirectly. By an amateur we don't mean the ten-year-old boy of your neighbor, who starts up a one-kilowatt spark set just when your family is enjoying an opera by radio, or when you are trying for a long distance record. We think that this kind of nuisance should be done away with at once, to keep the musical programmes free from spark splashes. A small boy with a big spark set is certainly a misfit in the present scheme of radio.

Many amateurs, however, are radio engineers, skilled in both the theory and practice of the art, and their activities do much to extend our knowledge of radio. They were the first to show the possibility of transatlantic communication by low powered, short-wave sets. In the tests recently inaugurated 33 American amateur stations were copied in England in the course of one day only, stations even as far away as California being heard there. This year a one-kilowatt

English station has been equipped to try the transmission in the opposite direction and undoubtedly many American amateurs will pick up its signals. In a recent all-American test, amateurs sent a message from Hartford, Conn., to Hawaii and return in four minutes! Radio workers who, by their enthusiasm, financial aid, and skill are performing these remarkable feats should be governed by legal measures only to the extent absolutely necessary for the development of short-wave transmission.

### A New Type of Power Tube

**A**T THE time that Dr. Hull was announcing the new detecting tube described above, the press contained a report of another development which had taken place in the same laboratory—a power tube capable of delivering one million watts of high-frequency power. This is not an ordinary three-electrode tube; it has only a filament and plate, the filament being a piece of tungsten rod nearly half an inch in diameter!

The action of this tube can be well visualized only by those who have become accustomed to the idea of electrons and their actions in magnetic and electric fields; to such the functioning of this new tube presents a fascinating picture. The filament is heated by a high-frequency current, of a frequency half of that which it is desired to generate; the cylindrical plate surrounding the filament is maintained positive with respect to the filament at about ten thousand volts. The electrons evaporated from the hot filament tend to proceed at once along radial lines to the plate, and they do so unless the current in the filament exceeds a certain critical value. The filament current, being alternating, passes through all values between its maximum positive and negative values twice per cycle, and this new tube is so designed that at the maximum values of current the magnetic field set up around the filament by its own current is sufficient to deflect the electrons from their normal path to the plate and make them describe curved paths which land them back in the filament, a short distance farther along than the point at which they evaporated. Their motion is much like that of a school of flying fish following a ship: they swim swiftly toward the surface of the ocean, arrive at the surface with sufficient velocity to overcome the effect

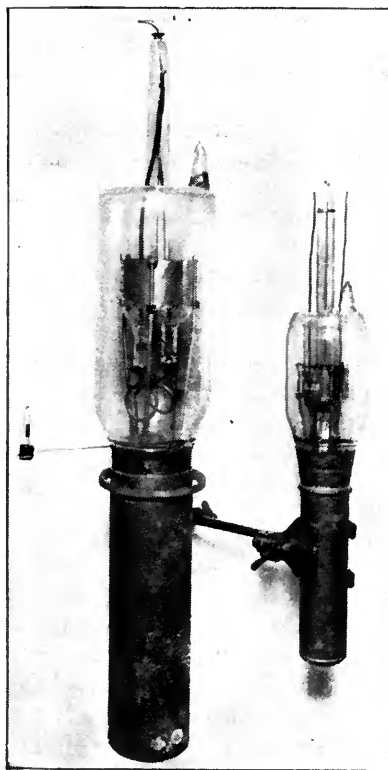

TWO GIANT POWER TUBES

A small receiving tube is shown in comparison

of gravity, break through the surface, and “evaporate” into the air; here they describe a curved path which lands them back in the ocean a few feet farther along than the point where they left it, only to “re-evaporate” perhaps a few hundred feet farther along their course.

In the case of the tube, during that part of the cycle when the filament current has low values, the electrons are not going back to the filament and so do get over to the plate. This action results in a series of pulses of current being delivered to the plate circuit, which pulses may be used to excite powerful oscillations in a properly tuned circuit. In this new tube the magnetism generated by the filament current itself performs the same function as does the grid in the ordinary three-electrode tube.

Where is the Radio Bill?

**F**OR many months we have been waiting for Congress to do something with the radio bill. It was introduced in the House early in June; in its substance it had the

endorsement of the membership of the Radio Conference called by Secretary Hoover to consider what should be done to further the progress of radio.

The bill as at first drafted by Mr. White was submitted to the Radio Conference. This body approved it generally, and made a few recommendations regarding minor changes, which were incorporated in the bill in so far as the advisory legal committee felt it possible to do so. The bill, then, represents the best thought of those executive and technical experts who have had most to do with radio development in America. The present legal status of radio is most deplorable, compared to what it might be if the provisions of this bill were put into effect, yet little or nothing is apparently being done to get the bill put through. With the bill passed, the wave-band allowed for broadcasting would be considerably widened over its present limits and practically all trouble from interference would disappear, even for the unskilled novice. The amateur investigator would have more latitude than he now has. So far as a layman's perusal of the measure discloses there is no political advantage to be gained by hindering the passage of the bill; it will not create new offices to be filled by deserving henchmen; its passage would apparently benefit Democrat and Republican alike.

Why, then, is there no action of the White bill?

### The Rapid Increase in Radio Traffic

**A** FEW months ago the statement was made by President Carleton, of the Western Union Telegraph Company that transoceanic communication was practically monopolized by the cables, that radio carried only 12% to 14% of the total business. Now we have the statement of Mr. David Sarnoff, Vice-President of the Radio Corporation, that of the transatlantic business radio is handling from 25% to 30% and of the transpacific business, 50%. Even allowing for the natural inclination of each of the proponents to exaggerate somewhat the importance of his own field, it seems that radio is actually making rapid strides in the race for long distance traffic.

During the recent elections, storms se-

riously crippled the western land lines, but the International News Service was able to maintain 100% activity through the help of the Radio Corporation stations. It is stated that the transcontinental business, handled over radio channels on short notice, was carried out so successfully that the New York to San Francisco service was as good as is obtained with the land lines in normal condition.

To fill in its comparatively idle periods, the Radio Corporation is offering a new and remarkably low rate-schedule for delayed service, six cents a word to England or Germany. This new service, styled "radio letter" service, permits the filing of a message, in plain English, any time during the week and delivery in Europe is guaranteed before the following Monday morning. Undoubtedly this will prove valuable to business houses with European connections; it permits the closing of a deal without delay, at a cost but slightly exceeding that of the much slower mail service.



### Copyright for Broadcast Material

**A**T THE request of the American Society of Composers, Authors, and Publishers, a meeting was held recently to consider the question of collecting royalties from the broadcasting stations which are sending out, by phonograph or otherwise, material which has been copyrighted by any of the members of the society. The society controls, through its membership, the copyrights on practically all the popular music of the day, including the so-called jazz music.

No agreement was reached as the representatives of the broadcasting companies required time to consider the proposition; many interesting views on the question, however, were brought out. The Society wanted to exact from a station a flat royalty rate, depending upon the number of listeners; such a measure evidently didn't look attractive to the broadcasters at this time because as this society controls but a small part of the material sent out, and as other composers and publishers have rights similar to those of the jazz writers, the total royalties which might be exacted under such a scheme might run into large figures.

Mr. Townley, for the Westinghouse Company, outlined the broadcasting situation very well and pointed out to the attorneys for the

jazz writers that the broadcasters were in a quandary as to where the money for the operation of the stations was coming from even with the present expense, let alone the extra expense which would be incurred by royalty collections. Although his company had sold many receiving sets, and this indirectly produced the money for running the transmitting stations, probably hundreds of thousands of sets were sold by others who had no connection at all with a broadcasting station and from whom copyright royalties evidently could not be collected.

We believe the society of jazz artists and publishers would do well not to press the matter; legally they cannot collect royalties from an activity which yields no profit and it is doubtful if the balance sheets of any of the broadcasting stations to-day show a profit. If the jazz is played at the transmitter station from a phonograph the artist has already collected one royalty and if the artists themselves appear at the station to perform, the advertising they get probably pays them for their trouble, otherwise they would not come.

### Power Transmission by Electron Tubes

WITH the advent of the recently developed tubes which have outputs reckoned in hundreds of kilowatts, there has appeared several times in the press the statement that these tubes would soon make possible the transmission of power by radio; some articles seemed to quote eminent engineers to that effect. It seems extremely unlikely that such predictions were ever made; the economical transmission of power by radio is no nearer solution to-day than it was when that brilliant scientist-engineer, Nikola Tesla, performed his well known experiments in this field.

We say "economical transmission" of power by radio because, of course, power is actually being transmitted, by radio, every day; every

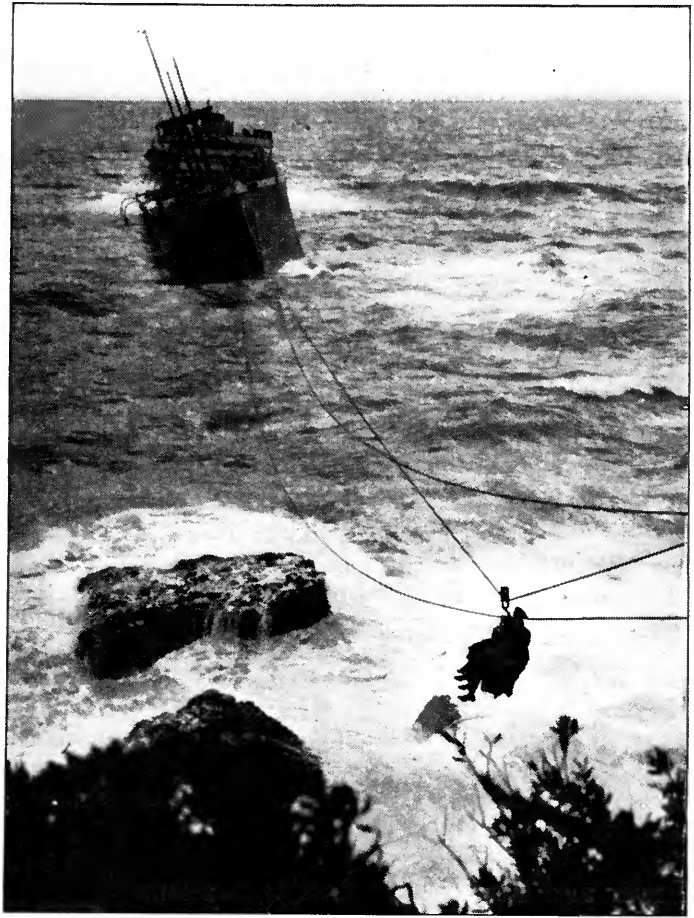

A STRIKING PHOTO OF THE WRECKED S. S. "WILTSHIRE"

Some may have read the account of this shipwreck which occurred during a dense fog and terrific gale last June off the east coast of New Zealand. Mr. Harmon Reeves, Consular Agent at Dunedin, N. Z., writes with reference to this event: "The wireless operators on the *Wiltshire* stood to their posts manfully, as most of these operators do on such occasions, and continued to despatch SOS calls as long as the plant remained in working order. Had the vessel been without wireless, it is more than likely not a man on board the ill-fated vessel would have been saved." Reaching the island and working under great difficulties, a rescue party finally saved the men in the manner shown. The picture shows the two junior operators being hauled ashore. (See Photo on

Page 273)

radio signal is an illustration of the action. But of the hundreds of watts sent out from a transmitting station only an infinitesimal part is picked up by a receiving antenna. Even when the combined action of all the receiving antennas is considered, the power sent out from the transmitter is nearly all wasted in empty space. The very fact that the power is radiated, or set free, to travel in an essentially spherical distribution, at once discourages the engineer who has ideas along this line. The

reason we use power transmission lines is to guide the electrical energy to the point where it is to be utilized; radiated energy is subject to no such constraint and it naturally tends to flow equally in all directions.

The reason the large electron tubes were at once associated with the idea of power transmission is that they are able to fill important rôles in the present transmission line projects; these new tubes may serve as rectifiers at the generating station, changing the alternating-current power of the generators to high-voltage continuous-current power for transmission over the long power lines and then reconvert it into alternating-current power at the place where it is to be used. This use of the electron tube seems to be a logical, in fact, almost certain development; continuous-current power can be economically carried over transmission lines much greater distances than is possible by alternating current, and because of this fact the new tubes may soon be serving in new long distance power developments; the power will not be transmitted as high frequency, radiated power, however, but as continuous-current power, guided by transmission lines of ordinary construction.



quality of the voice could be completely spoiled by poor wire transmission before it even reaches the radio station. Under these conditions the signal will be poor no matter how excellent the radio station itself may be. Thus if a transmitting station receives its signal over a hundred miles of wire, installed to handle ordinary land telegraphy only sufficiently well, instead of getting the signal over what is called a high quality telephone circuit, the broadcasted signal will be of poor quality.

Some kind of an agreement should be reached between the various interests involved so that any qualified radio station may use the highest grade line available to bring the voice currents to the modulator. If this is not feasible, such a station should be allowed to broadcast only from microphones located at the station, so that the wires connecting the microphones with the modulator can have no bad effect on the quality of the signal. Broadcasting from a distant microphone should be attempted only by that station having the highest grade wire connections available. In this way alone will the quality of broadcasting improve as we should like to see it.

### Fewer and Better Broadcasting Stations

**W**E HAVE several times expressed our views on this question, and as we see the art develop, our convictions along this line become more firmly fixed. It is now technically possible to send out broadcast messages of excellent quality, as the achievements of station WEAF (N. Y. City), for instance, have proved. The engineers responsible for this station evidently know the requirements for good voice transmission and have succeeded in getting it. Of course they, of all people, should be able to do just this thing; their research workers have spent years in studying this problem and their engineers know what voice frequencies are important and what are not and how to make the microphones and associated apparatus function properly.

Another important factor contributing to the success of WEAF's broadcasting is the knowledge of and control over high quality telephone lines. Many times the microphone which picks up the sound waves is miles away from the radio station and evidently the

### The Passing of the Navigation Officer

**T**HE navigator of the modern ocean vessel probably knows his position at all times to within a very few miles, no matter what the weather is. Time was, when it was a matter of guesswork as to what weather a ship was going to encounter and as to just when land would be sighted. Radio is largely responsible for the increased certainty of the ship's position and prospects. Are the chronometers correct? Twice a day they may be checked with the standard clocks, which, by radio dashes, throw out their reassurance over the thousands of square miles of ocean. Is there rough weather with storms ahead? A radio inquiry to a ship 500 miles ahead on the course at once eliminates the doubt. The "make everything fast" order may be given long before a threatening sky gives warning of the impending blow. How about the ship's position when nearing the harbor? A request for radio compass bearings will enable the navigator to locate his position on the chart to within a fraction of a mile. The radio compass may then pick up and follow the hum of a



submerged cable laid in the channel, sending off audio-frequency signals, and thus it may steam into the harbor without ever having sighted land.

All these things have already been accomplished, and are in use every day. They are not the possible, but the actual things science has accomplished during the last quarter century.

And now there comes to the further aid of the navigator another scheme of communication which will help to make his position doubly sure. As a result of certain researches carried on during the war, part of which have been disclosed, it is possible to get soundings of the ocean's depth by echoes. A sound-generating apparatus in the ship's hull sends straight downwards a pulse of sound which will reflect from the ocean's bottom and return to the ship to actuate a microphone which produces the echo for the listening operator. The time elapsing between the sending of the original signal and the return of the echo serves to give accurately the depth of the ocean. The ocean's floor can now be accurately and quickly mapped and accurate charts of its topography can be plotted; the navigating officer then

times the sound on its trip to the sea-bottom and back to the surface, and by comparison with the chart he at once checks his position which has been determined by other methods.

For shallow water where the echo would return too rapidly to permit an accurate determination of the time taken for the sound to travel to the bottom and back, another scheme is used, which does permit of very accurate measurements of the depth. A special listening device is located at the bottom of the vessel and it can be so turned that the listener hears the echo of the screw of his own vessel, this echo having been sent back by the ocean's bottom. Knowing the angle to which the device must be turned to get a maximum echo, and the length of the ship, the depth of the water can be determined to less than a fathom.

During certain tests in which the writer took part, it was found possible to recognize the ship's position in the harbor by the quality of the echo returned by a sound beam sent in towards the shore; in certain positions only one sharp echo would return, in others perhaps three or four, of different intensity and in some positions no echo at all came back. Here,



#### THE MORNING AFTER THE NIGHT BEFORE

Showing the S. S. *Willshire* divided into three sections; the stern has disappeared. The men, who had suffered frightfully from exposure, hunger, and thirst for 36 hours, were all saved

then, is another possible help to the navigator. It seems that the days of lead lines and dead reckoning are rapidly being relegated to the tales of the sea. The navigating officer practically never has to use his judgment in finding his position; with modern communication schemes he *knows*.

### Radio Surgery and Doctoring

**T**HE maritime law requires that any ship carrying passengers shall have a doctor on board, but there are thousands of vessels such as freighters, tankers, fruit boats, fishing schooners, tramps, etc., which carry no doctor; a case of pneumonia or a broken leg must be treated by the ship's cook, or someone equally unskilled in the practice of medicine. A patient's chances of adequate attention are evidently rather slim.

Many of these boats do carry a radio outfit, however, and more of them are continually installing equipment, for reports on docking

facilities, market conditions, etc., which may be received by radio make the investment pay. On such boats skilled surgical or medical advice may now generally be tuned in; cases are being reported daily of emergencies being successfully met by advice sent by radio. An example is that of a man whose broken leg was amputated by the cook; a description of the condition of the injured man having been sent by radio to the surgeon on a liner 200 miles away, detailed directions for the operation were wireless back and the cook (already equipped with suitable tools) successfully "did the trick." We may not relish the idea of being put through such an operation, but if it is necessary, the radio instructions without doubt make the cook a safer bet than if he were left to the dictates of his own inspiration.

With an adequate medical outfit on board and a good doctor within radio range, the wants of the crew of the doctorless boats will be much better taken care of than they have been in the past.

J. H. M.

### THE HIGHEST RADIO STATION IN THE WORLD

The site is the peak of Mt. Corcovado, 2,100 feet above the city of Rio de Janeiro, Brazil. Workmen erecting the aerials experienced many thrills, when the slightest mis-step would have meant a plunge to the depths below



# The Boy Scout's Place in the Radio Game

By ARMSTRONG PERRY

Sea Scout Radio Commodore, Boy Scouts of America

**T**HIRTEEN out of every hundred of the radio listeners who cursed at the Government for putting a talk on cancer into the air the other night at the beginning of the radio concert hour, will die of cancer—unless they can secure the repeal of the law of averages. The only way to avoid it is to acquire individually the information broadcasted at that time and live up to it. Pneumonia, typhoid, tuberculosis, heart disease and kidney diseases will carry off a large percentage of the remainder, and will do it years earlier than they need to, unless they take the common-sense precautions suggested in the broadcasts of the United States Public Health Service.

One hundred per cent. of the commuters who missed their trains yesterday and blamed the erratic alarm clock could have reached the office on time if they had spent a minute or so listening to the clock at the Naval Observatory in Washington announcing the hour at ten the evening before. It can be heard in any American home, for its ticks are carried to the remotest corners of our country on radio waves rolling out from the Navy station at Arlington, Virginia and others along all our coasts. These same commuters could have carried their umbrellas and avoided their last wetting if they had spent as much time practicing the International Morse Code as many of them spent on bridge, and listened for the weather forecast that followed the time signal. In fact they need not have learned code, for there is a boy in every neighborhood who would get it more easily and who would delight in copying code broadcasts and passing the information to his neighbors if he had a little encouragement.

Out of the ninety per cent. of business men who make a failure of their enterprises, according to statistics, a fair proportion might win success by making intelligent use of information that is collected on an enormous scale by our Government and shot out in concise form by radio or held in reserve awaiting the day

when the public asks for it. One American citizen out of every 157 is an employee of the Federal Government and a large part of the 672,953 persons on the pay roll are engaged in collecting, tabulating, and disseminating useful information. By radio it can be transmitted, received, and used in less time than it takes a messenger to carry copy for a Government pamphlet from a Department building to the Government Printing Office.

And yet, with true American prodigality, a lot of us twist the knobs on our radio receivers, screw up our faces and superheat our tempers in trying to tune out the Government broadcasts, and as a nation we permit more than two hundred efficient Government radio stations to stand idle for forty per cent. of the time, when they might be adding to our enjoyment and prosperity. Worst of all, we waste almost one hundred per cent. of a natural resource more valuable even than our much discussed water power, namely, *our boy power*.

The present-day radio situation is made up of diverse elements. There are well-established governmental and commercial services which only a few far-sighted individuals are using fully. There are the commercial broadcasters who bear an enormous expense in filling the air with entertainment that sells their competitor's goods as well as their own. There are manufacturers and dealers who never know exactly whose alleged rights they may be infringing when they sell a piece of apparatus that has been made in cruder form by thousands of boys without let or hindrance. There are the amateurs and experimenters, the pioneers of radio, who, from the often unjust viewpoint of listeners who are interfered with by their dots and dashes, are as exasperating as the mosquitoes whose hum their code resembles. Outnumbering all the rest are the radio users whose aim when they sit down at their sets is to be amused.

A theatrical manager who built a stage and dressing rooms but no orchestra section, balcony or box office would be called a fool. A



#### SCOUTS RECEIVING INSTRUCTIONS IN VARIOUS SYSTEMS OF SIGNALING

Members of this St. Louis troop took up radio a long time ago. The picture was made in January, 1914

college that provided courses and faculty but enrolled no pupils, leaving the matter of attendance up to the loiterers who drifted by, would be held up to ridicule. A newspaper that gives away its daily edition on the street free of charge is seldom taken seriously by its readers and never by the reliable advertiser. Yet millions of dollars yearly are being spent in broadcasting entertainment and information by radio with no more definite or complete checkup as to results than the post-cards and letters sent in by those who listen.

So far as has been discovered, the first suggestion to the effect that there should be organization at the receiving end of the broadcasting came from the Boy Scouts of America. Or it might be more just to give the credit to the Navy Department. During the war the Navy and the Army found that the main source of supply for competent radio personnel was the "amateur." These amateurs, most of whom were self-taught, came forward in large numbers and filled the gap while the Government and private schools were getting under way with the task of developing operators and radio experts by thousands. After the war, the Navy planned to conserve the interest of the coming generation of amateurs by organizing a Radio Amateur Bureau in the Third Naval District and transmitting daily an Amateur Broadcast. These broadcasts were in a sense personal messages

to the amateurs who were registered with the Bureau. To give them the piquancy of secrecy they were often transmitted in a code which could be readily translated only by the use of a key furnished to the members of the Bureau. Sometimes a message was addressed personally to an individual.

One of these messages was picked up by a scout official. He copied the amateur broadcast night after night thereafter, became convinced that the system had great value, and scraped acquaintance with the Navy officers in charge. The Navy officers, limited as to appropriations, suggested that the Boy Scouts of America, the largest uniformed force, civilian or military, in the United States, might be of service by encouraging the registration of amateurs with the Bureau. Immediately the Scout organization accepted the assignment. A Seascout Radio Commodore was appointed to serve as a liaison officer. To give the arrangement greater force the Bureau began broadcasting for the Scout organization anything it wished to transmit to its local units. This all happened four years ago.

Since then the Army, the Post Office Department, and other governmental departments have established broadcasting schedules. The Boy Scout organization, with these programmes as additional talking points, has redoubled its efforts to encourage Scouts and others interested in radio to receive what

the Government transmits and give it local distribution.

Having more than half a million Scouts and Scout officials distributed throughout the United States in more than 20,000 communities, it is perhaps the only civilian organization that is in a position to develop local receiving stations for national broadcasting on a national scale. The Post Office Department is the only governmental agency that has as many representatives so well distributed for the purpose.

The "cute little Boy Scout," as doting grandmothers and enthusiastic aunts are apt to call him, is in fact almost a man. His average age is about the same as that of George Washington at the time when he surveyed a large part of the Shenandoah Valley for Lord Fairfax. It is above fifteen and one-half years. While scouting recently with M. C. Hopkins, President of the Cave Men's Club of America, the author found the name of the Father of his Country carved on the wall in the remotest chamber of a cave near the end of the 1748 survey, together with what appeared as though it might be the skull of a goat used in the Masonic ceremonies that old histories say Washington conducted in this chamber. He concluded that the boys of pre-Revolutionary days were much the same as the Scouts of today, except that their elders granted them more freely the privilege of undertaking man-sized jobs.

The Radio Amateur Bureau, for the further encouragement of operating ability on the part of radio scouts, reserved the numbers from 1 to 100 on its membership list for Scouts who would learn to send and receive code at the rate of twenty words per minute. One of the first scouts to meet the requirements was Lyman F. Barry of New York.

Scout Barry's record is an example of the way many Scouts are going after radio, heart and soul. He received his first radio training in his Scout troop and built a crystal set at his home in 1917, getting it into operation just about in time to dismantle it in obedience to the war order issued by the Government. He kept up his code practice and after the war often operated the headquarters transmitting station of the Manhattan Association of Radio Scouts, having received an amateur operator's license. Registering with the Radio Amateur Bureau some time before he could qualify for the reserved list, he improved his speed and was



LYMAN F. BARRY

Whose record as a Scout during the war and later shows a keen interest and exceptional ability in radio. He is now a Scoutmaster in charge of a New York troop

promoted from No. 345 to the second place on the list in 1920. Then, at the College of the City of New York, he served as secretary and vice-president of the radio club, and experimented with several transmitters of spark and continuous-wave types. For receiving, he has built a three-circuit honeycomb coil regenerative set with a two-stage amplifier.

By authority of Colonel Holden, the commanding officer, Scout Barry operated the U. S. Army station at Camp Devens, Mass., during the summer of 1920. Several times he has kept Scout camps in touch with the world when his radio gave them their only prompt communication. At the time of the *Roma* disaster he gave the first news of it to citizens of Geneseo, New York, where he had his set.

By 1922, he had passed an apprenticeship as Assistant Scoutmaster, reached his twenty-first birthday, and qualified as a Scoutmaster in charge of a troop. The troop, No. 503 of Manhattan, camped at Redding, Connecticut, last summer and for the first time in its history this little hamlet was in immediate touch with the world, through the Scouts' radio. "Reports and the weather luckily agreed very nicely," reported Barry, "and we became quite believed in during the two weeks we had camp there."



A "PUSH-CART" SET

One of these Kansas City Scouts is pulling on a guy-rope fastened to a mast made of scout poles lashed together

At present, nine of his Scouts have radio sets, four of which are good tube sets. Radio instruction and practice in town and on hikes are part of the routine. Stopping to rest under any convenient tree, they get a wire aloft and are immediately in contact with the world.

Radio Amateur No. 3, after serving in the Brooklyn Council's scout camp for a season, became a commercial operator while still very little above the average age of Scouts. He

made trips to the West Indies, Panama, South America, and Europe. Between jobs he gave his services to the largest Scout camp in America, bringing in news from all parts of the globe and transmitting headquarters traffic to the local units.

When the public stampeded for the radio-telephone broadcasts a year ago, he was invited to take a position which, had radio personnel been more plentiful, would have been filled by a man twice his years. A patent situation developed that led to a quick change in the management, and the Scout went to a radio store as a clerk behind the counter. One day he discovered that he, like others who had been connected with the manufacturing plant, was under the surveillance of detectives acting on behalf of a big radio corporation, whose rights were alleged to have been infringed. He was asked what he did when he discovered that he was being watched, "I got acquainted with the detective and sold him a receiving set," he answered.

Radio Amateur No. 4, Orin Livingston, and No. 5, Howard J. Wendler, serve the Scout troops in Roselle Park, New Jersey and go with them to their summer camp. Both hold amateur first grade licenses. No. 6 is Ralph Woodruff, also a first-grade amateur operator, who until recently worked his own and another Scout station at East St. Louis, Ill.

No. 8 is a Brooklyn amateur, David Talianoff. He is assistant scoutmaster and radio operator in Troop 97. His "fist" is well known to amateur operators, for he transmits not only



A RECEIVER THAT COST TWENTY-ONE CENTS  
A Scout is explaining its construction to the author

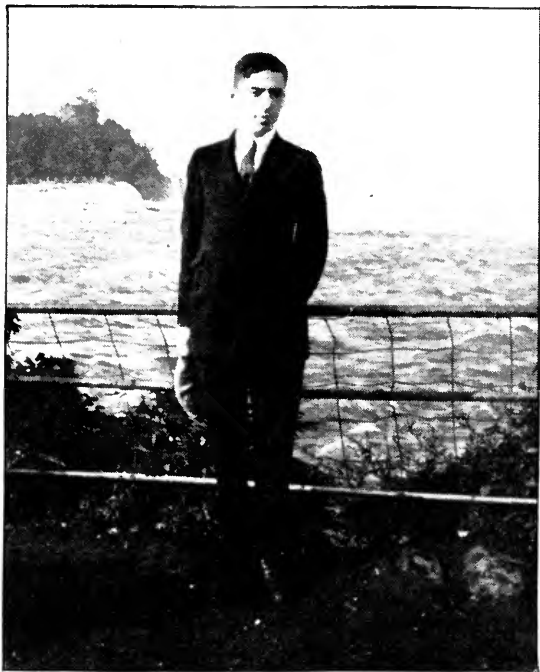

RADIO AMATEUR NO. 8

Assistant Scoutmaster David Talianoff at Niagara Falls

from his own station, 2PF, but also from 2FP at Brighton Beach, N. Y. This station is said to be one of the most efficient in the United

States. It is heard in every state in the Union and has been reported even from Hawaii, France, England, and Germany. He gives much time to handling the citizen messages relayed by the American Radio Relay League. Three of these taken at random from a crowded log book show delivery the same day they were filed, at such scattered points as Brooklyn, Cleveland, and Robling, Ontario.

The ambition of the radio Scout is as different from that of the technical radio amateur as the job of the automobile racer is from that of the rural postman and his flivver. The technical amateur is striving to get distance, the Scout to give service. When the technical amateur has sent a message farther than any amateur ever sent one before he is satisfied—for the moment. When the radio Scout has picked up and delivered in his community the information that it wants, he is satisfied—until he is needed again. He gets it from the nearest Government station that broadcasts it because that makes its reception most certain. The technical amateur incidentally handles a good many useful messages, and the radio Scout incidentally acquires a good deal of technical ability. When technical ability and the scout spirit are found in one individual it makes a very strong combination.



2FP, SOMETIMES USED BY TALIANOFF

Whose "fist" is well known to amateurs. This station has been heard in every State and far beyond the boundaries of the continent

In some places the radio training of Scouts has been highly developed. At Donora, Pennsylvania, there is a Boy Scout Radio Experimental Unit composed of boys of Italian, Finnish, Austrian, English, Slavish, German, and Scotch parentage. In 1921 an Eagle Scout, that is, one who has earned the highest award for scoutcraft, visited the town and talked to the Scouts about radio. Thirty-five of them formed a class that night and those who had to ask Dad before joining came in the next day.

From then on there was no rest for Deputy Scout Commissioner McCune, who took charge of the bunch. He took them to camp and they studied electricity and magnetism. After they returned home they did not give him a chance to get a bath and shave before they were asking when the first meeting would be held there. They overflowed from his experimental station and the Commissioner had to appeal to his Council for larger quarters. Within a week the School Board granted the

use of a room with electric light, running water, 'neverything. The Scout Council appropriated a hundred dollars for equipment. Work benches, a store room, and lockers were built. A local plant donated sixty-five pounds of magnet wire and a wood turning lathe. A motor was installed to turn the lathe. Models for variometers, variocouplers, transformers, and other apparatus were provided. There were three classes a week, with a half hour of theory and three times as much practice. Radio books and magazines were always available.

The membership grew until there were 110 in the class. When the public school closed last June, day and night work had worn the Commissioner to a frazzle. He did not admit it until he was laid up for two months. When he recovered he organized the Unit with ten members. "I make every effort to secure them odd jobs of work," he reports, "and they always perform as Scouts should." He enrolled in a well-known correspondence school which granted him the privilege of permitting all his Scouts to use the lessons and equipment that it sent him.

In fourteen months this group has entertained three thousand visitors with radio concerts, from stations hundreds of miles away in many instances.

Rear Admiral H. J. Ziegemeier, U. S. N., Director of Naval Communications, recently sent a message to the Boy Scouts of America "covering the reasons why Boy Scouts should be encouraged to receive regularly and distribute locally the broadcasts transmitted from Naval radio stations for the benefit of the public." "Your wonderful organization teaches you," he said, "that your greatest happiness in life comes from serving others. In receiving and distributing the information sent out by radio stations, you bring to others information that your experience and observation teaches you means but one thing—greater happiness in life."

The Admiral's argument hits the bullseye. But it is hard for an organization composed largely of boys, and with less than one per cent. of its official personnel on the salary list, to take the initiative and bear the whole burden of a service that will bring to a community daily the up-to-the-minute information that it needs and wants. The community should at least ask for the service and encourage the Scouts by thus letting them know that they are reckoned as an asset in the affairs of the public.

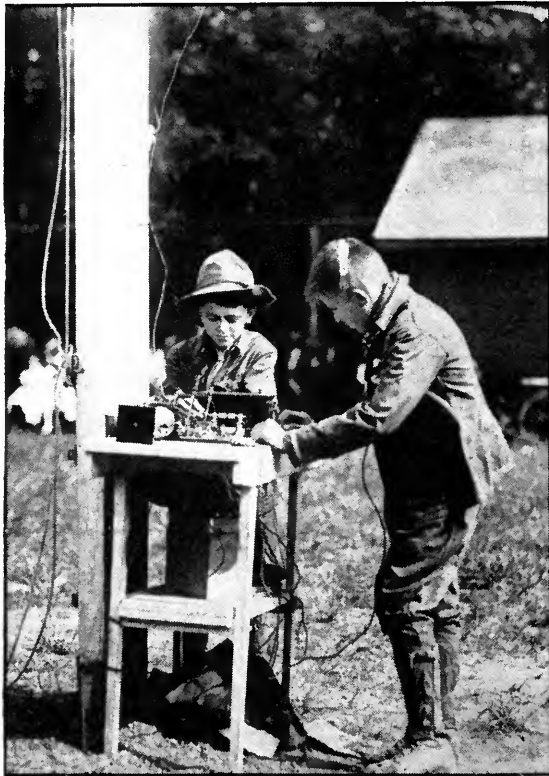

#### TWELVE YEARS AGO!

This picture, taken July 4, 1911, shows 1st Class Scout Pickering and 2nd Class Scout Ziefman of Troop 1, Roslyn, L. I., operating a spark-coil set. Compare this picture with the frontispiece, showing modern apparatus used by members of the same troop



There are other services for radio Scouts to perform besides picking up and distributing weather forecasts, market reports, and other Government code broadcasts. The radio horizon has been considerably broadened within the past few months by the work of a little-known inventor who is referred to above as the President of the Cave Men's Club of America. An expert in acoustics, he turned his attention a year ago to the problem of making radio a community feature as well as a hobby for an individual and a pastime for a household.

At his lodge in Waterford, Virginia, he erected a seven-foot cement horn with a loud-speaker mechanism of his own design. With any of the ordinary types of tube receivers he can bring in concerts, lectures and sermons so that they can be heard at a distance of two miles or more, yet with a mellowness that makes it agreeable to hear them within his own gates. No printed advertising is necessary. He merely tunes in the show and his audience assembles. There is little in Waterford to prevent their attendance at any time. That is what he is thinking of—the lack of things to keep the boys busy, useful, and self-respecting.

It is as plain as the stars and stripes on our flag that the present situation in radio, plus the status of the Boy Scouts of America, gives practically every American community an op-



A VERY LOUD SPEAKER

Built by Mr. M. C. Hopkins, President of the Cave Men's Club of America, on his place in Waterford, Va.

and whatever other broadcasting it may wish to receive, and at the same time develop the character of its boys by giving them useful things to do. All it needs is a man who will make radio service his hobby and an organization such as the local government, the Chamber of Commerce or the Rotary Club to boost it. Music and setting-up exercises in the public schools, business information, news from the ships at sea, diplomatic details from the capitals of the world—one is as easy as the other when Boy Scouts learn radio and use it for the public good.

February, 1923, brings the Thirteenth Anniversary of the Boy Scouts of America. Here's a wish for many happy returns of the occasion with an ever

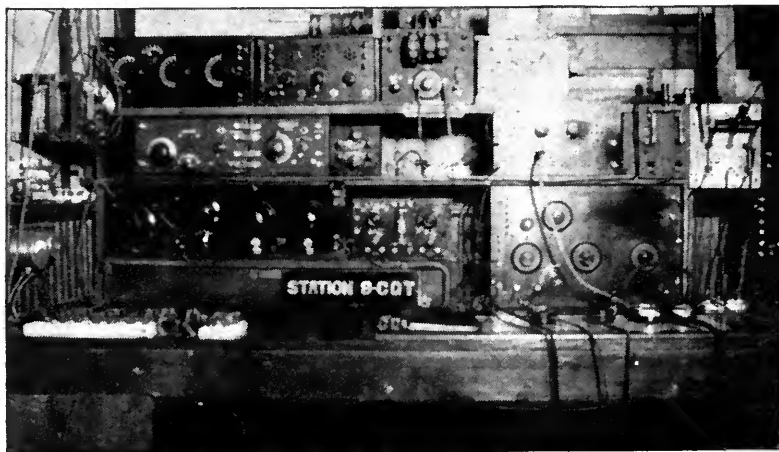

THE SCENE OF GREAT RADIO ACTIVITY

This is Station 8CQT, built and operated by the Boy Scout Experimental Unit at Donora, Pennsylvania

portunity to organize a radio service that will insure the receipt of all Government broadcasting, whether in code or by radio telephone,

increasing number of members ready to minister to their community and spread the example of unselfish service.

# This Radio Bill We're Hearing About

By CHARLES H. KESLER

Member of the Bar of the District of Columbia and New York Patent Law Association

ALTHOUGH closely associated with the radio industry for several years, my practical experience was slight. But last fall, I became impressed with the intensely human side of it, as opposed to the radio of diagrams and technicalities. The boy next door had a set which was perfect (having made it himself). The boy was decidedly a radio bug. When he insisted that I try his set, I placed the phones to my ears, and instantly, through the ten-cent crystal (Woolworth), I was receiving the football scores and cheers. It was then that I "discovered"—as so many thousands had done before me—that radio is a great thing, that it is here to stay, and that, if there is any dissatisfaction with it, the causes of this dissatisfaction could be and should be removed.

A new law is being proposed for this very purpose. Work was started on the bill some time ago and is nearly finished. In what follows, I am offering a few tentative suggestions and pointing out certain features of the proposed legislation which may set people working on the bill and for the bill.

The problem presents certain difficulties; but none of them are insurmountable, and they will be solved, with the help and suggestions of all. Radio must be built upon a rock, for we cannot progress without firm foundations and without a goal which we are determined to reach. Our goal is the highest possible development of radio, and the foundation is law, reasonable and just.

The new radio legislation, which has the potentialities required, is designed to prevent interference and to make broadcasting practical and of service to all. But just what is there in this proposed bill or this legislation?

The proposed radio legislation is embodied in two identical bills: the House Bill H.R. 11964 introduced by Mr. White of Maine and the Senate Bill S3694 introduced by Mr. Kellogg. The House Bill was referred to the committee on the Merchant Marine and Fisheries and the Senate Bill to the Committee on Interstate Commerce.

The proposed Radio Bill amends the present

radio laws as embodied in the Act of August 13, 1912. Before the amendment can be understood, what is being amended must be known. Let us briefly consider the Acts now in force.

The earliest law now on the statute books is the Act of June 24, 1910, as amended, which requires ships licensed to carry fifty or more passengers, to have radio apparatus. This Act would remain in force under the new laws.

The spirit and purpose of the present laws is well summarized in regulations promulgated by the Secretary of Commerce as follows: "The principal purpose of the regulation of radio communication, international and national, is to secure the greatest efficiency of maritime communication through this agency, especially as a means of promoting safety to life." The new law proposed extends the purpose to broadcasting.

The Act of 1912, which enlarges the scope of the radio laws for the purpose of saving life, remains in force under the proposed legislation with the exception of Sections 1, 2 and 3 which are replaced by others in the bill now pending, and with the exception of Regulations three and four of Section 4 relating to the use of a "pure wave" and "sharp wave," which are repealed. Certain other slight changes are also made in the regulations.

The regulations of Section 4 made by Congress are for the purpose of preventing or minimizing interference and to facilitate radio communication, but these may be waived by the Secretary of Commerce at his discretion when no interference can ensue.

These regulations provide that every station shall be required to "designate" a wavelength as the normal sending and receiving wavelength of the station. Every ship station, with exceptions, and every coast station open to general public service must be prepared to use two sending wavelengths, one of 300 meters and one of 600 meters as required by the international convention in force, which convention is the law of the land. With exceptions, all stations may use other wavelengths.

At important seaports and where interference occurs between government stations and

other stations, a division of time may be made by the Secretary, the Government sending only during the first fifteen minutes of each hour, and other stations sending the remainder of each hour.

Private stations not engaged in commercial business or experimentation are limited, without special authority, under the regulations, as amended to wavelengths between 150 meters and 275 meters and to a transformer output not exceeding one kilowatt. This applies especially to amateurs.

No station not already in actual operation shall be licensed for the transaction of commercial business by radio if within fifteen nautical miles of the following government stations: Arlington, Key West, San Juan, Porto Rico, North Head and Taloosh Island, Wash., San Diego, Cal., or which may be established in Alaska or in the Canal Zone. The above are the main features of the regulations which will remain in force under the proposed legislation.

Section 6, which also remains in force under the proposed legislation, defines "radio communication" as follows:

"Sec. 6. That the expression 'radio communication' as used in this act means any system of electrical communication by telegraphy or telephony without the aid of any wire connecting the points from and at which the radiograms, signals, or other communications are sent or received." Will not this definition soon become obsolete? What about wired wireless? Have not high-frequency oscillations been transmitted over the network of wires and rails connecting the Pacific with the Atlantic, even without the knowledge of the Telephone Company and Railroads, and without disturbing the normal operation of their lines? Do we not plug in lighting circuits to receive these messages? Is it not possible that it is wired wireless?

The United States is a party to the London Convention, but its provisions and regulations apply only to stations on shipboard and to coastal stations open to general public service. This treaty, therefore, will not limit or prevent effective legislation for the adequate control of our domestic radio situation.

The difficulties involved in harmonizing the various interests desiring to utilize radio communication are enormous. Certain of these interests are now recognized by the

Department of Commerce and are classified as ship stations and land stations. Land stations are of two classes, coast stations and inland stations. Coast stations are stations which transmit messages to vessels at sea or on the Great Lakes or whose operation can interfere with the exchange of such messages. Inland stations are those which cannot transmit such messages and which do not interfere with such messages, depending on geographical position or range. Both coast stations and inland stations are divided for the purpose of the administration of the Act of 1912 as follows:

- (1) Public service stations
  - (a) general
  - (b) limited
- (2) Limited commercial stations
- (3) Experimental stations
- (4) Technical and training school stations
- (5) Special amateur stations
- (6) General amateur stations
- (7) Restricted amateur stations



All coast stations, except general and restricted amateur stations, must be able to transmit on the wavelengths of 300 and 600 meters for the purpose

of relaying distress signals. These are the international standard wavelengths agreed upon by treaty between the United States and other nations. All coast stations are required to listen in every 15 minutes on 600 meters to determine if any distress signals are being sent. General public service is defined as "paid business" conducted on commercial wavelengths between ship and shore, or between ship and ship.

Limited public service is "paid business" between certain designated land stations, ships or line of ships.

Limited commercial stations are not open to public service and are licensed for a specific commercial purpose. The nature of the remaining types of stations, it is believed, will be obvious.

The interests or classes interested in radio may be additionally or differently classified as follows:

- (1) The Federal Government (Army, Navy, Commerce, etc.),
- (2) The large class of persons interested in broadcast reception and using receivers,
- (3) Manufacturers and dealers (including the big fellow and the little fellow),
- (4) Broadcasting agencies, and
- (5) General public.

How are these various interests to be brought into cooperation on the principle of live and let live? The public is interested, because, if the radio industry is not in a healthy condition, it affects all, it lowers the general prosperity. A system of broadcasting which approximates the ideal means that people will want sets in increasing numbers. That means greater enjoyment, more business, a more satisfactory state of affairs for the people as a whole. The enactment of suitable legislation to approach this ideal condition, even though it remains an ideal, should receive the hearty cooperation of all the people and of their representatives in Congress.

Obviously any law that flexibly covers the situation and takes care of all classes must be more or less general in terms and yet of such character that injustice cannot be done by officers in executing the law. The law should operate automatically as far as possible, considering the volume of details which cannot be covered other than generally by law.

The only proper authority for controlling the radio situation is the Federal Government. But within the Government are various interests, the Army, Navy, Commerce and other departments. There will always be more or less friction between these several departments as long as one of them is placed in control. It is as if one of the parties to litigation acted as judge. Yet the best possible broadcasting system can be worked out only with the cooperation of these several departments.

The logical control would be a super-departmental control by the President or his representative. The new bill places the control in the hands of the Secretary of Commerce with one exception—the President is authorized to assign wavelengths to the Army and Navy. Of course, we might do well to have a Director of Radio just as we have had a Director of Railroads, etc., but the Secretary of Commerce has in the past controlled the situation and as the head of the Department of Commerce, the matter comes very properly under his supervision.

The proposed bill is, like most original bills, indefinite and inaccurate in places—but it is, in general, good. At least, all interests are taken care of while securing the best possible broadcasting conditions.

The Secretary under the new bill is the final

judge on the matter of granting licenses. No appeal to a court is possible. A writ of mandamus cannot be issued to compel the Secretary to grant or renew a license. Under the law now in force the applicant can have his day in court. Whether or not it is necessary to give the Secretary this autocratic power to control broadcasting properly I am not prepared to say. At least the matter should be thoroughly considered before passing the bill.

It must be admitted that such authority if rightly exercised, would be beneficial, yet to favor one's friends is not natural. The granting of a station license under "the proposed act and its renewal is 'in the discretion' of the Secretary. Certainly if a person has operated a station satisfactorily for ten years, he should have his renewal and it should be dependent upon the whim or political motive of the Secretary. The granting of original licenses must depend on all the facts in the case, whether or not there will be interference. But even here there is the possibility of favoritism, and no recourse to a court is possible.

Section 2C provides that the Secretary may grant a license only to a station which is in the interest of the "General Public Service." A better expression could be used here in view of its acquired meaning, referring to a commercial station sending messages for pay as defined above. Construing this clause one way would rule out amateur stations.

Section 1C provides that government stations not used exclusively for communication of official business are subject to control by the Secretary of Commerce and licenses are required. Government stations used exclusively for official business shall use such wavelengths as are assigned by the President. Furthermore, they must observe "such regulations" as the Secretary of Commerce "may" (why not "shall"?) make to prevent undue interference. These regulations can be suspended by the President in time of war. This is all very good and shows that the officers of the Army and Navy who were on the committee which framed this bill are for doing everything they can to further the cause. Certainly if there is any point to be cleared up, it can be taken care of to the satisfaction of a great majority of the people.

The proposed law is also more stringent in regard to aliens. Under the present law citizens or domestic corporations can secure sta-

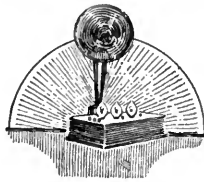

tion licenses. Under the proposed law even a domestic corporation cannot secure a license if one alien be a director or officer or if a fifth of the capital stock having voting power be owned or controlled by aliens. There is grave doubt as to the wisdom of or necessity for such restrictions. If there must be restriction as to a domestic corporation, it should be based on whether or not the corporation is in fact controlled by aliens. Certainly one alien director does not necessarily control a corporation nor does merely a fifth of the stock.

Section 2C is as follows:

"The Secretary of Commerce is hereby authorized to refuse a license to any person . . . which, in the judgment of the Secretary, is monopolizing or seeking to monopolize radio communication, directly or indirectly, through the control of the manufacture or sale of radio apparatus or by any other means. The granting of a license shall not estop the United States from prosecuting such person . . . for a violation of the law against monopolies or restraint of trade."

I don't know why this clause was made a part of the bill. At any rate the authority given here is unnecessary as the Secretary can refuse a license, "in his discretion," for any cause whatsoever. The whole thing is opposed to our fundamental scheme of government which separates the legislative, judicial and executive departments. Here the Secretary of Commerce is the judge. His judgment (or opinion) is final. If he thinks a company is a mono-

poly, it is. The printed record in the famous anti-trust cases would put the five-foot library of Doctor Eliot to shame, but with all the voluminous records before them, courts differ as to whether an organization is a monopoly or not. They even differ as to what a monopoly is. They may be lawful, such as a patent mono-

poly. Is the Secretary going to try the case before passing judgment? And as a climax to show how right the Secretary's judgment might be, the granting of a license is not to estop the government from bringing suit under the Acts provided for that purpose, putting the poor monopoly to further expense! Why not let the courts pass on monopolies and the Secretary on licenses. Unlawful monopolies are bad, but certainly this clause does not remedy matters.

Adequate provision is also made to enable the Secretary to revoke a station license whenever the owner of the station fails to obey the law or any regulation or "whenever the Secretary of Commerce shall deem such revocation to be in the public interest." The clause quoted is broad enough to allow the Secretary to revoke the license for almost any reason. The licensee or owner may have a hearing, how-

ever, on the matter of such revocation, but only before the Secretary.

Other clauses of the bill regulate the granting of operators' licenses and their control. No alien can be granted a license nor any representative of a foreign government. Manufacturers and importers of radio apparatus should

### Keep Your Eyes Open!

Following a report that the radio legislation, prepared as a result of the Conference called by Mr. Hoover last February, had been "pigeon-holed," RADIO BROADCAST invited all the editors of radio publications in the Metropolitan District to attend a conference to decide upon a definite form of action to relieve the jam existing in the ether. This meeting took place November 6th, last, and was followed by a similar meeting in Pittsburgh, Pa.

The fact that legislation was essential and urgently needed was recognized by all, and a resolution was passed at both meetings to get the proposed bills out in the open and through the necessary legal channels.

Cognizance was taken of the weak points in the proposed bills but no time was lost in attempting to weed out the objections—that was left for *you* to do.

The National Radio Chamber of Commerce has prepared data of a technical nature, derived from questionnaires sent to all branches of the radio industry and other organizations have done likewise. It is quite likely that the technical aspects of the new legislation will be satisfactory to most of us, if due consideration is given the conclusions arrived at after a comprehensive study of such questionnaires.

However, it is essential in altering any legislation to be certain that the new is not even worse than the old—for it is possible for laws, in the hands of artful lawyers, to be distorted beyond recognition and made to defeat their own purpose. We must have some relief from existing conditions, but we must be sure that the relief is not temporary, to be followed by a relapse into some worse malady.—THE EDITOR.

visé the parts of the bill relating to restrictions on aliens. For instance, under Section 2B, a "representative" of an alien or of a foreign government cannot be granted a station license even though an American citizen or an American controlled corporation. What does "representative" mean? What does it cover? While these restrictions are apparently war measures they do tend to restrict importation of foreign apparatus. These restrictions of the proposed bill should be given full consideration at the hearings. Let the light of day shine upon them.

Under Section 4, a permit is required to start the construction of a station. This does not apply, however, to amateur stations and government stations used exclusively for official business. If the station is not constructed within the time specified in the application for permit, the latter is automatically forfeited. Why this is necessary I don't know. Nor does the granting of a permit oblige the Secretary to grant a license after the station is finished. Build the station first, and then take a chance on securing a license!

Section 5 provides for an advisory committee, acting as advisors for the Secretary. It is suggested that one of the matters on which this committee should report is broadcasting. The committee is to comprise twelve members, six from the government departments and six non-government members of "recognized attainment in radio communication," to be appointed by the Secretary.

Section 8 permits the Secretary of Commerce to impose a penalty for perjury! Even though this section be constitutional, it seems to me that the use of a transmitter without a license should be made a misdemeanor, the court having jurisdiction of such cases as well as of perjury. Of course, the Secretary should be able to revoke a permit or license when

obtained fraudulently and to impose penalties for violation of regulations in cases where licenses have been granted or to revoke the license.

I have merely touched on points of the bill which to me seem to need revision or amplification. It is believed that the bill will meet the recent phase of radio communication, that is, broadcasting, which must however remain subordinated to the use of radio for safeguarding or saving lives at sea.

The committee whose conferences resulted in this bill have done their work well. It may be advisable to incorporate in the act other of their recommendations made in their report, such, for instance, as prohibiting point to point radio communication, direct advertising, etc., instead of leaving it to regulation by the Secretary.

The Bureau of Standards should be empowered to make a complete study of the radio situation in all aspects. This can be done by suitable appropriation and enlargement of authority by Congress, if such power and money are now lacking.

This committee also recommended that the Secretary be empowered to prohibit the use of receivers which cause the radiation of energy. It is believed that, if any prohibitions are necessary, the law should positively so provide. While certain foreign countries now prohibit the use of such receivers, the enactment of such a law would render useless important and valuable patents as well as thousands of sets now in use, unless it should exempt sets now in use.

There, then, is the bill—a bill to put across even with its defects. This act is the foundation on which the future of radio broadcasting will depend. Every one of us should get back of it, offer suggestions, and push it hard. Let's get busy!



# The Facts About the Loud Speaker

By G. Y. ALLEN

**B**EFORE the invention of the vacuum tube, the telephone head set was the universal device for recognizing radio signals. At that time it was necessary to use this highly sensitive device in its most efficient way, as the detectors in use were inefficient, to say the least.

With the coming of the vacuum tube, however, the situation became entirely different. Infinitesimal voltages received on the antenna may now be amplified to the point where they can be used to operate a relay if necessary, so that the extreme sensitivity of the telephone receiver is no longer essential. With the development of the vacuum tube came broadcasting, and the novice soon outgrew the limitations of the head set. The owner of the radio receiver is no longer typified only by the boy amateur intent on getting distance; for the business man—the home owner—as well, is now an enthusiast. The present-day novice wants concerts and educational programmes so that they are audible to the entire family without the necessity of wearing head sets. Thus has come the loud speaker and with it the emancipation of broadcast reception.

Early attempts at loud-speaker design were confined to attaching standard head telephone receivers to horns of various kinds. One of the earliest was the application of a telephone receiver to a phonograph. The reproducer was removed and by a special fitting, the receiver was attached to the tone arm, thus affording all the desirable characteristics of the phonograph tone chamber. The receiver with its

fitting is illustrated in Fig. 1. Another attempt along the same general lines was to provide a horn with one or two openings at its smaller end to which the head set was clamped.

While the art was in its infancy, the quality of transmission was poor, and such makeshifts were endured. As the quality of broadcast-

ing improved, however, two outstanding defects were noted. The quality was far from that heard on a head set and the amplitude was not enough for all purposes. Almost all developments in loud speakers in the past year have been along the lines of improving the quality and quantity of the received signals.

To have a loud speaker faithfully reproduce sounds is one of the most complex problems facing the manufacturers today. There are any number of loud speakers on the market, but it is generally admitted that none of

them has yet attained perfection.

Any loud speaker functions in two distinct ways. First, it must take the electrical impulses delivered to it by the vacuum tube and convert them into mechanical motion, then this mechanical motion must be transformed into air waves. Neither the electrical system nor the acoustic system can be designed separately, but both must be developed together.

One aim in the design of the electrical part of the loud speaker is to get the diaphragm to vibrate with the same amplitude at all musical frequencies that may be used for the same applied voltage to the terminals of the loud speaker. The ear is capable of hearing about eleven octaves, and the range of musical

## In Search of a Loud Speaker

There is no such thing as a perfect loud speaker, any more than there is a perfect human being. Science, however, is ever trying to improve existing conditions and the loud speaker is receiving a great deal of attention.

There are some loud speakers, designed by acoustic and electrical experts, that produce even better music than the phonograph—but there are a great number of loud speakers capable of no speech whatever. Makeshift loud speakers, like makeshift shells, are usually “duds.” There is plenty of room for development in this interesting field.

In this article, Mr. Allen tells something of the difficulties to be overcome, the present methods in general use and the hope of an early solution to the problem. Following, as it does, “How Your Telephones Work,” which appeared in our January number, this article should be of especial value to those of our readers whose interest in sound reproduction has induced them to try to surmount the difficulties met in loud speaker design.—THE EDITOR.

sounds runs from about 40 vibrations per second up to about 4000. The range of the human voice extends from about 60 for low bass notes to about 1300. A good loud speaker, therefore, must cover these ranges without distortion.

The point of first importance is to insure that the forces acting on the diaphragm faithfully reproduce in air waves the variations in current that come to the loud speaker. To accomplish this end, designers of the electrical mechanism must be governed by certain physical laws.

A conventional loud speaker receiver mechanism is similar to that of a standard telephone receiver and is shown in Fig. 2. To the poles of a permanent magnet are attached two soft iron pole pieces on which the coils are wound. Supported very close to the pole pieces but not touching them is the iron diaphragm.

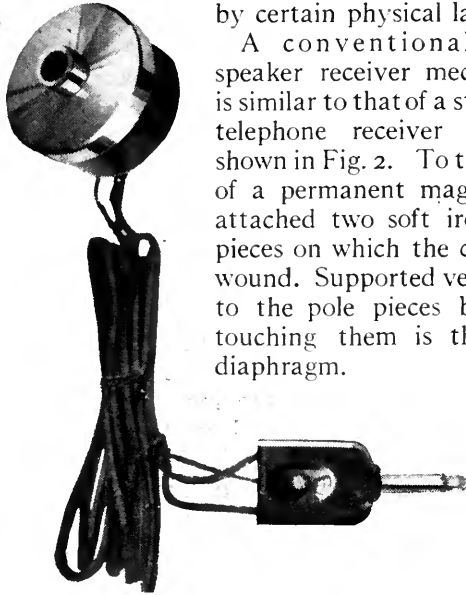

FIG. 1

Telephone receiver designed to fit over phonograph tone arm

When a variable current is sent through the winding, the pull or attraction of the pole pieces for the diaphragm varies, thus allowing the diaphragm to vibrate. It should vibrate with an amplitude proportional to the current strength. To insure this, the length of the air gap must be small which, therefore, limits the amplitude of vibration, and thus the volume of the loud speaker, by the diaphragm coming into contact with the soft iron pole pieces. A loud speaker constructed as shown in Fig. 2 is therefore limited as to the volume it can produce.

Now the variation in pull on the diaphragm depends on the variation in current in the winding and also on the number of turns of wire. As the currents used at the radio receiver are very minute, very many turns of wire are needed on each bobbin. To get a

large number of turns in the space available, the wire must be very small in diameter, which means that the electrical resistance of the winding is high. In a well designed loud

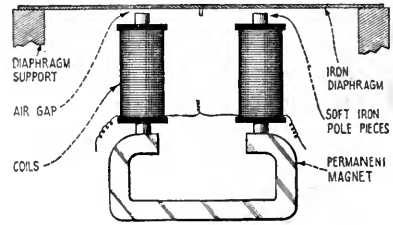

FIG. 2

speaker, therefore, the resistance of the winding is a measure of the "current sensitivity" of the instrument.

In radio, the loud speaker is generally connected in series with the plate of an amplifier tube as shown in Fig. 3. For loudest response, the alternating voltage or pressure caused by the incoming signal should be the same between the plate and filament of the loud speaker. This condition cannot be completely met as the voltage across the loud speaker varies with the voice frequency whereas the voltage across the tube remains nearly constant regardless of frequency. It is customary to make the voltages approximately equal at some voice frequency such as 500 or 800 cycles per second.

As the voltage depends upon the "resistance" or "impedance" of the tube and loud

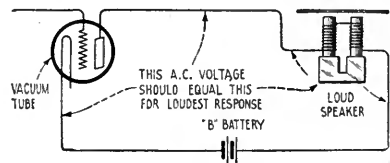

FIG. 3

speaker, the impedance of the loud speaker is generally made equivalent to that of the tube. Standard tubes have an impedance of about 20,000 ohms, and loud speakers should have an impedance of about this value at 500 to 800 cycles for maximum volume.

Sometimes it is more convenient to wind loud speakers to a lower impedance. In this case, a transformer must be interposed between the plate circuit of the tube as shown in Fig. 4. This transformer has the larger number



of turns connected in series with the plate and the lower number of turns connected to the loud speaker.

One very important feature to guard against in the design of the mechanical part of a loud

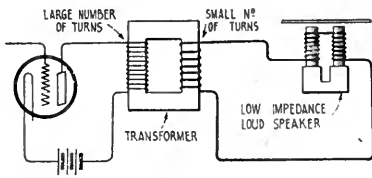

FIG. 4

speaker is mechanical resonance. All mechanical systems have a natural period of vibration, and if they are subjected to vibration forces of this period or frequency, they will respond with an amplitude far out of proportion to the applied force.

Fig. 5 shows graphically how a loud speaker diaphragm would respond to a range of frequencies including its own resonant frequency. In such a test, the voltage across the loud speaker or the current would be maintained constant. A loud speaker designed with a moving system whose natural period fell within the range of voice frequencies would distort horribly and would be practically worthless. All well designed loud speakers, therefore, aim to have the natural period of the diaphragm and moving system well above the range of the human voice or musical instruments.

Although the electrical and mechanical design of a loud speaker is involved, it is simple when compared to the design of the horn and sound chambers. In spite of the

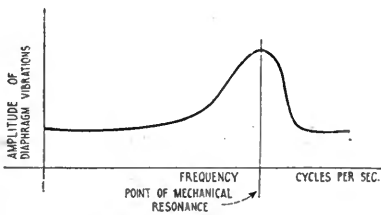

FIG. 5

large number of loud speakers now on the market, it is pretty generally acknowledged that a very large amount of research work must yet be done before a loud speaker that is absolutely distortionless is evolved.

Most of the development work on loud speaker horns and sound chambers have been

of the cut and try variety, and the human ear has in most instances been the means by which the quality of the different designs was measured. Now, it is extremely difficult to get two people, when listening to a loud speaker, to agree on fine differentiations in quality. It is an interesting fact that many people prefer a loud speaker which apparently distorts somewhat. Loud speakers that throttle the acid quality of a musical production and accentuate the string and wood wind instruments seem to be preferred, and yet such loud speakers will show obvious distortion on speech. In short, the successful design of a loud speaker is a most involved problem which has barely been touched as yet.

It was early discovered that the material from which the horn was made had an important bearing on the quality. It was found necessary to make metal horns from dead metals such as zinc, lead or cast aluminum. Horns made from wood and wood fibre, cellu-

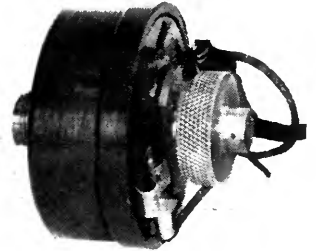

FIG. 6  
The loud-speaking unit of a device which uses an adjustable magnet system.

loid, hard rubber and such non-metallic materials give a very pleasing quality to music, but it cannot be said that they do not distort. It has been found that the horn must be adapted to the particular loud speaker and a horn that would give good results with one mechanism may be totally unsuited for another.

Loud speaker development has progressed along two distinct lines. One type has been similar to the conventional telephone receiver in construction in that the diaphragm, made from iron, is subjected to the magnetic force and also sets the air in motion. In the other type, the diaphragm is mechanically attached to an iron vane on which the magnetic forces act. The diaphragm serves only to set the air waves in motion in this case.

One loud speaker of the first type is essentially an aluminum casting, into the base of which are screwed two telephone receivers of the same type that are used in the head set manufactured by the same company. Such a

loud speaker is limited as to volume but will give sufficient sound intensity for a small room, when used with a two-step amplifier. Another loud speaker of the first type uses no permanent magnet. The magnet system, however, is adjustable by means of a threaded nut, which in the complete loud speaker is operated

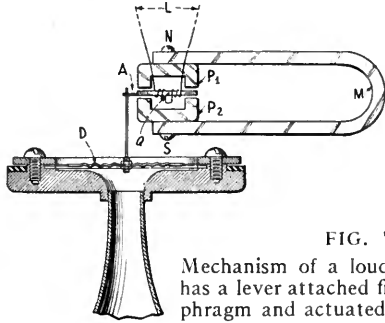

FIG. 7

Mechanism of a loud speaker which has a lever attached firmly to the diaphragm and actuated by the magnet

from the outside of the box. In this way considerable control of the volume and quality is obtained. Fig. 6 shows the loud speaking unit of this device.

To permit of greater amplitude in the motion of the diaphragm and still maintain a small air gap, various lever systems have been introduced into loud speaker designs from time to time with varying success. The danger arising from such a procedure of course is the introduction of distortion. There is the possibility of increasing the weight of the moving system to the point where it will be objectionable and also the air resistance may reach such a point as to interfere with rapid motion. Furthermore, great rigidity in the moving system is essential or the loud speaker will "rattle."

Fig. 7 illustrates the interior mechanism of one type of lever action loud speaker that has proved highly successful. M is a permanent magnet provided with two soft-iron pole pieces P<sup>1</sup> and P<sup>2</sup>. Suspended between the poles of this magnet is a soft-iron armature, A. A is pivoted at its centre in the



FIG. 8

The horn is non-metallic

centre of the pole pieces in such a way that it can oscillate within limits. Surrounding the armature and supported by the pole pieces is

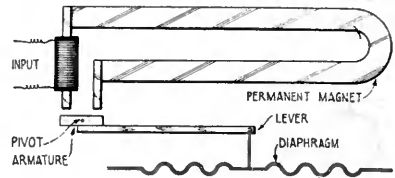

FIG. 9

the coil, consisting of a large number of turns of very fine wire. The armature has attached to it at one end a small rod mechanically connecting it to the corrugated diaphragm.

When a current is connected to the coil through lead wire L, one end of the coil is instantaneously north and the other end is south. An inspection of the sketch will show that this form of field will add to the flux on one side of the armature and subtract from it on the other side on both ends of the armature. This will cause the armature to tend to rotate about pivot Q, thus displacing the diaphragm. A reversal of the current will cause a displacement in the opposite direction.

As will be noted from the sketch, the distance from the diaphragm rod to the pivot is

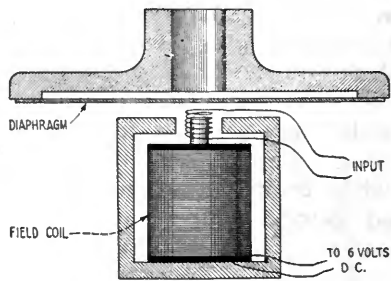

FIG. 10

about twice that from the middle of the pole piece to the same pivot. For any motion of the armature in the air gap, therefore, the motion of the diaphragm will be about twice as great. Great volume can thus be obtained from a loud speaker of this construction and distortion can be kept at a minimum.

Fig. 8 shows the loud speaker complete with a non-metallic horn. This horn is especially designed to produce the minimum of distortion and the metallic quality is, of course, entirely lacking.

The internal construction of another loud

speaker of the same principle is shown in Fig. 9. Here the armature is affected only on one side by the magnetic flux, and its movement must be kept down to a very small amount to maintain the length of the air gap small. A long lever is thus necessary to obtain sufficient displacement of the diaphragm.

This particular instrument is provided with a mica diaphragm which combines great flexibility with lightness. It is mounted on a stand in such a way that it can be rotated in any direction.

A loud speaker of a design differing from any of these mentioned is sketched diagrammatically in Fig. 10. In this case, no iron diaphragm or armature is used. Instead, there is attached to the diaphragm a coil that vibrates with the diaphragm. This coil is connected to the energizing source and vibrates in the field of an electromagnet, M. This magnet is energized from a 6-volt direct current source.

This construction gets away from a direct operating instrument being limited in its amplitude of vibration by the length of the air gap. In fact, it is claimed that practically any volume may be obtained from this instrument. A photograph of this loud speaker is shown in Fig. 12.

In general, good operation of a loud speaker at moderate volumes may be obtained by connecting it directly in the plate circuit of the last tube of a two-stage amplifier. This cir-

cuit will give good results in the home where it is desired to fill but a small room. There are cases, however, where more volume is desired. In fact, at times it is desired to make music and speech audible to crowds of people assembled in the open air. The power available from a two-stage amplifier becomes totally inadequate in such cases.

To get the necessary amplitude for large volumes, it is necessary to use additional stages of amplification with tubes that are capable of delivering very much more power than can be obtained from an ordinary receiving tube. The use of these tubes entails high plate voltages and heavy consumption of B battery energy. The resulting volume, however, is remarkable. Speech and music have been made easily audible over distances of more than a mile.

Fig. 11 illustrates an amplifier designed for use with the loud speaker shown in Fig. 8. It consists of two stages, using three tubes. The tubes are capable of delivering considerable power and the last two are connected in such a way that the loud speaker is supplied with the sum of their outputs.

The plate circuits of the last two tubes are connected to a transformer having a split primary and the sum of their effects is impressed by transformer action on the secondary which is connected to the loud speaker unit.

In conclusion, it might be said that the manufacturers of loud-speaking devices have accomplished wonderful results when the time they have been working on them is taken into consideration. The problem is extremely involved; but we cannot doubt that before long vast improvements will be made and that we shall see the day when broadcasted material can be made audible in practically any volume without distortion.



FIG. 12



FIG. 11

An amplifier designed for loud speaker use

# N A A

By DONALD WILHELM

**A**T NIGHT, visible from all directions for miles around, there are now three lights glowing atop the Arlington Towers, one six hundred feet up, the others four hundred feet up from the hill that looms above the Potomac overlooking Washington. The towers of NAA, and these lights, now constitute a landmark for the aviator, signifying that he should bear off a bit southeast, or swing over the Washington Monument, the Capitol and the Navy Yard, and that Bolling Field is underneath. With the coming of planes and of radio, what a changed aspect this Arlington hill has taken on since George Washington and Major L'Enfant stood there, as tradition has it, and planned the city of Washington!

Not so long ago, when an amateur radio convention was about to assemble in Washington, more than three hundred of its delegates were asked what landmarks they desired most to see in and about the Capitol: should the Capitol come first, or the White House, or should it be NAA? Back came the post-card replies, almost unanimous for NAA. The giant on the hill has a distinct personality, and has long been immensely popular with thousands of acquaintances. It has had some great experiences, too. In February, 1920, for instance, there was that memorable snow and sleet storm that for whole days tied up nearly every railway wheel on nearly every railroad up and down the Atlantic Coast. It concentrated on Arlington. "Our antenna then consisted," said Charles Range, who is still in charge of the station's crew of six men, "of three wings, triangular in shape, each consisting of two spreaders eighty-eight feet long and each weighing 3,000 pounds. There were twenty-three wires in each wing, there was ice eight inches in circumference on each wire—eleven tons of ice on each wing, thirty-three tons altogether, if you figured it out, after that sixty-mile gale did its darnedest. Well, the evening of February 7, 1920, about 7:30, there were three reports that sounded like a battleship coming on the range—the first sounded like a three-inch gun, when the shackle in one of the insulators gave way, the next was a 14-inch gun,

when one end of the antenna parted from the big tower, and the last sounded like the explosion of the whole works, when that débris buried itself in the frozen ground."

But the point in all this is, not that the station kept working for two days before the last wing crashed, but that, during the ensuing six days, mariners, jewelers, farmers, amateurs and others, by radio, by telegram, by letter, and in sundry other ways, transmitted one long wail to the Navy: "What in the world has become of our old friend, NAA?"

And there were others who addressed themselves to the Secretary of the Navy, and to their Congressmen and Senators, about like this: "Save money if you have to, but for heaven's sake give us back NAA!"

NAA has a bigger circle of friends in fact than any gentleman we know. If service rendered is immortality, in radio history this station will always be what it is to-day—as much a landmark and institution as almost anything east or west of the Potomac.

NAA has given more service to more agencies and people and to the progress of radio itself than any other station. One can safely go further and say that its original 100-KW Fessenden spark set, which now seems as ponderous and noisy as a steam shovel, has given more service than any other set in existence. It is still hard at work, with its heavy rotor and forty-eight glistening tractors not much the worse for wear. It is still serving hundreds of people who are equipped only with crystal receivers. Yet, progress in radio is so rapid that this much-celebrated set with its 200-hp motor and belt drive is likely to be retired before many more years, and there is a movement on foot, which all loyal devotees of radio will join, to set this old fellow up in the National Museum for the benefit of posterity, with an inscription about like this: "Here lies the original set in the first high-power station. From February 13, 1913, until arc and tube sets supplanted it, it was a good neighbor and a friend in need to hundreds of thousands."

NAA, remember, was the first of the Navy's chain of high-power stations—that chain which, when combined with American Private

Enterprise, Inc., absorbed links from Germany's supreme chain, links from Britain's imperial chain, and in less than a decade gave America the world's radio supremacy and a more effective guardian of such international understanding and peace as is possible these days than any other agency on earth.

It was from NAA that the human voice first leaped the Atlantic. Very early in that morning of October 22, 1915, a little group of Naval officers and others were routed out of bed to be told that they might hasten to Arlington and from there talk to other Americans in the Eiffel Tower, with the bustle and roar of a thousand guns only a few miles away from Paris and the Tower itself used as a target now and then in the daytime. They talked, and were heard in France and at Pearl Harbor, in the Hawaiian Islands at the other side of the world. There's an epic in itself—how American Enterprise,

Inc., perfectly confident that we would have to enter the war, went secretly to the Navy in 1914, explained that it wanted to lend a hand to the Navy by developing the radiophone with the help of such facilities as the Navy alone could offer, and how, with the Navy, it put up a wooden shack beneath NAA's big towers, went to work, and came through, that October morning.

It was via Arlington, too, on September 29, 1915, that the human voice, Mr. Vail speaking, was first transmitted from New York to the Mare Island Navy Yard on the Pacific Coast, via land wire to NAA, then via ether westward.

It was NAA that first broadcasted a President's voice, and it has been NAA that has enjoyed all sorts of similar but less important distinctions. When the argument, spark vs. continuous wave, was raging, and the Navy wanted only the better system for the rest of its

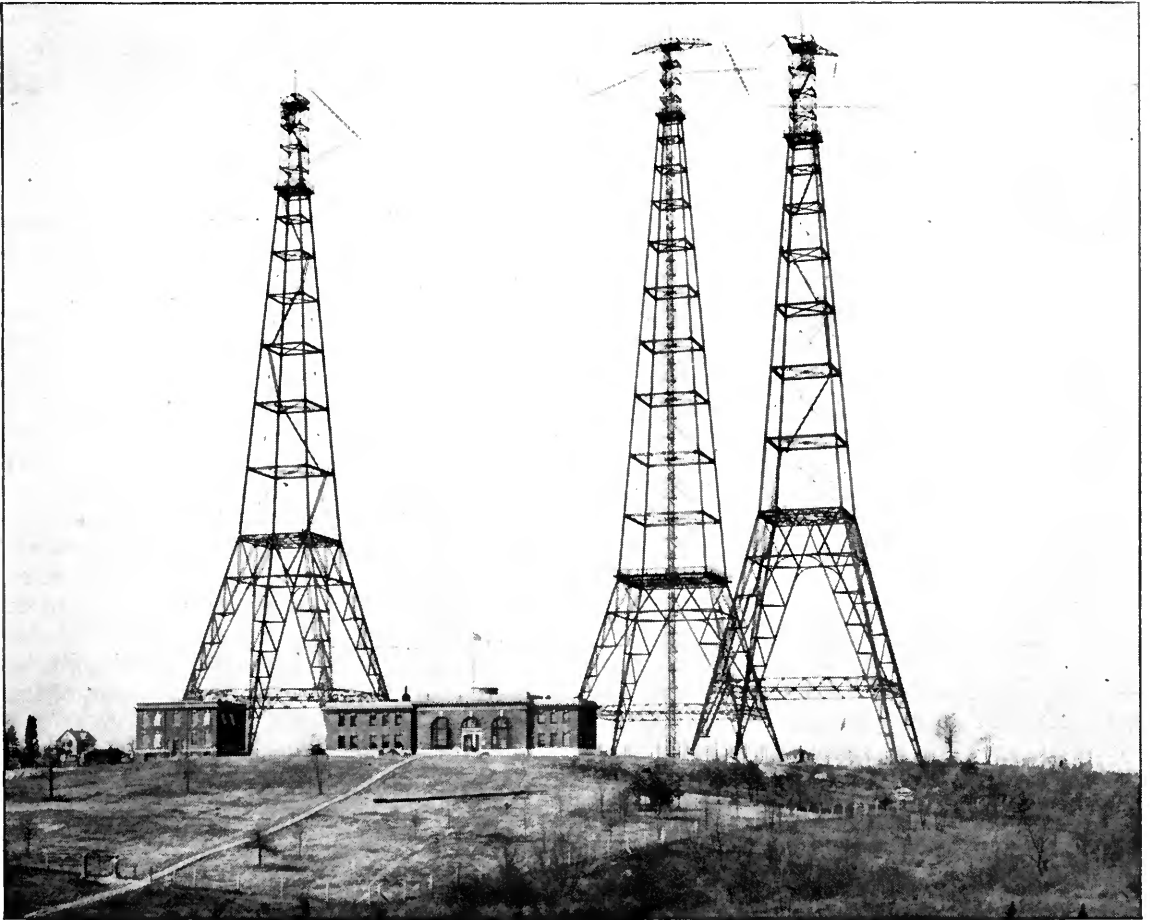

THE BEST KNOWN RADIO STATION IN THE WORLD

NAA, Arlington, Virginia, whose distinctive spark note is heard every noon and evening by thousands of people, both afloat and ashore, who tune in to keep posted on the time, news, and weather

chain, it was NAA that served at the land end while a cruiser, the *Salem*, moved eastward toward Gibraltar with experts on board, testing out both systems. And now, at the end of a period of not quite ten years, the same station is making experiments with tube sets, with the result, perhaps, that before long the Navy will be satisfied that even NAA's C.W. sets are destined for the National Museum.

Some years ago, the question arose as to whether a big and a little set could be worked at NAA simultaneously without the big one burning out the little one. There were those who declared it couldn't be done. It was Commander Hooper, as the story goes, who was one of those who said: "Let's try." So, it seems, suiting the action to the word, he pressed the keys of both sets at once,—and nothing disastrous happened.

Again, in 1915, authorities doubted whether the Navy Department, hardly more than half a mile from NAA, could receive with an antenna atop its own building while NAA was transmitting. Up the flag-pole of the State, War and Navy Building an antenna was run, with a wire down to the telegraph room. That worked. Now there is no receiving at NAA and no gob hammering a key either—receiving is done via a 5-wire antenna strung half the length of the new Navy Building just over the Potomac from NAA's big hill, and sending is done from a booth on the top floor of that building, by land wire and automatic key—by remote control, in other words. That's why, in the brick building hard by, but still entirely separate from the main radio building at NAA, you find two rooms, having doors half a foot thick with soundproofing and walls quite as thick, of which the doors are no longer closed. And that's why, in the smaller of these rooms, on a narrow shelf fastened to the wall, you see eight keys in a row and likely as not a couple of them working automatically, while perhaps the spark set next door is snapping or the C.W. or tube sets work in the adjoining building with nary a sound except the low hum of motors.

Now, after you've climbed NAA's big hill and looked about—at the neat brick buildings faced with limestone, at the towers rising high above you, at the fine lawn and flower gardens, at the wonderful view of Washington, and at other interesting things in and about the station (it cost originally only \$300,000, by the

way, and is maintained with a crew of six men at a cost of only \$18,000 a year), you wonder how they guarded this station during the war, and what happened. It dawns on you how fine a site it has—and that means a lot. You realize that there are no mountains, hills or big buildings anywhere near to divert or absorb electrical energy. You realize that NAA is far enough inland to be fairly safe from any attack except that of enemy aircraft, which might more likely make the Capitol itself the target. You see that the site adjoins Fort Myer; that there are ample sources of outside power; that the place, with screen protectors about the base of the towers and barb-wire entanglements all about its 16½ acres was, with a guard of marines on duty, safe enough from even pro-enemy fanatics. "But *did* anything happen?" you want to know.

"Nothing much."

"Well, what?"

"Well," your informant confesses at last, "not a doggone thing happened except one night."

"Then what?"

"O nothing! You see we had the wire entanglements all charged with just enough current to hold anybody that touched them. That particular night, a society flapper that took a fancy to one of the Marines, and I can't see that, tried to climb over, and he tried to help her. The searchlight picked up this romantic picture, the guard stopped the yells, and the flapper was sent home to mother!"

But there are other things you want to know, all in short space, about this giant and what it means to the Navy and the nation. The ground system is particularly interesting. It is a checkerboard of wires buried from 14 inches to two feet, extending over the entire 13½ acres of the original reservation. All of these wires are bonded at crossings. At one side of the reservation they terminate at a running brook and all are brought together at two sides of the transmitting building.

Above this checkerboard, resting on blocks of Vermont marble, with the ground switches evident enough, rise the three towers with their 1050 tons of steel.

These three main towers—there are now two new 200-foot ones receiving a final coat of paint—form an isosceles triangle with a base which runs magnetic north and south. The main antenna is lowered with electric winches



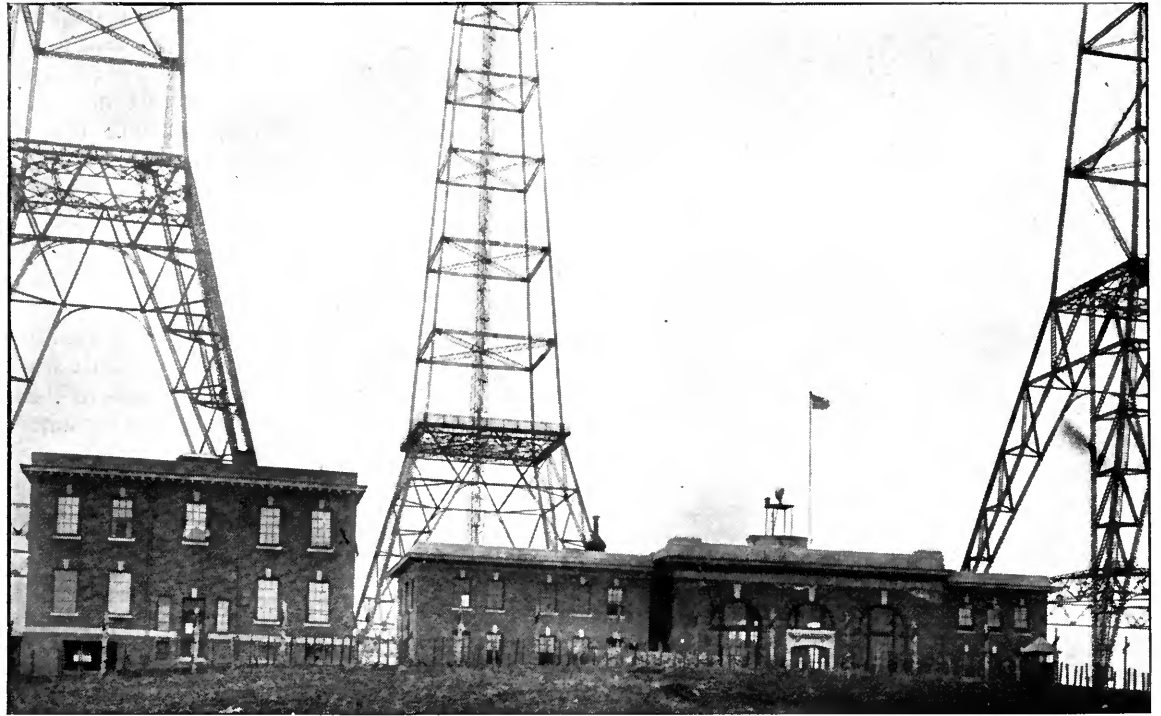

THE ARLINGTON HILLTOP IN WARTIME

Showing a part of the barbed wire barrier which was charged with electricity as a reminder to the mean or meddlesome

twice a year for inspection and overhauling. At the peak of the highest tower, by the way, there is now a wind-recording instrument tracing its records on a paper cylinder in what used to be one of the transmitting rooms. It is precisely 790 feet above sea level and it operates automatically, with no added labor for the Weather Bureau. East of the station about 100 yards rise the two new towers, each with an antenna strung back to the 400-foot towers. The Army built these in cooperation with the Navy, and they are on ground owned by the Army.

So there are now five sets of antenna, at NAA. These, with the new towers, indicate that, though the Navy Department is handling its own and other Federal long-distance work via NSS at Annapolis, NAA, at the advanced age of not quite ten years, is setting out on new ventures. It has long been sending out time, hooked up to the master clock at the Naval Observatory—but this is an old story. It has long been sending out, every day, weather reports and ship orders. Also Naval press news, so that mariners in and out of the Navy, shore stations up and down the Atlantic Coast and remote agencies and individuals innumer-

able have their daily newspaper, including the baseball scores, the football scores, almost everything except the morning murder.

You have only to consider what time, one of the constants in navigation, means to mariners, as well as to jewelers, to realize a phase of the service NAA renders when, at 11:55 A.M. and 9:55 P.M., the warning dashes flash out three or four thousand miles in all directions, followed by the longer dash that says "noon" or "10 P.M." exactly, 75 degrees meridian, Washington. Or go out with the Atlantic Fleet, see how the news is welcomed, and you understand even better what service that old spark set gives. Or consider what the weather forecasts mean to farmers and mariners. Yet these are only part of NAA's work. A big bulk of official orders, warnings about lightships out of position and of derelicts and icebergs,—to help prevent disasters like that of the *Titanic*—Shipping Board orders and re-routings, and thousands of other messages for the Navy or other Federal departments are all handled via NAA.

But this isn't all; for while NAA is giving over much of its former long-distance work to NSS, the more powerful near-by Annapolis station, it is going about the business of greatly

enlarging its usefulness in other directions. On that 7,416 square feet of floor space of the main building, which includes a well-equipped machine-shop and much other equipment in addition to motors from one-fourth horsepower up to 220, there are now six sending sets: (1) The spark set; (2) a 500-cycle A. C. tube set, for local work, such as traffic with New York, Boston, etc., and with ships out of range of shore stations along the Atlantic Coast and for Army work via one of the new antennas; (3) a 30-kw arc set for Navy long-distance work traffic to Guantánamo, Key West, Cuba, etc., for broadcasting general information from other Departments, for aeronautical reports, weather reports, etc. This set is going almost twenty-four hours a day and uses the big antenna mainly; (4) a 250-watt tube set for airplane work, using, generally, a secondary antenna swung between the two 450-foot towers; (5) another 250-watt tube set using the big antenna, for speeches, concerts, etc; (6) a long-wave 1200-watt telephone tube set, for band concerts, talks by the President and Cabinet, etc., with which the large antenna is also used.

Three of the sets use, it will be noted, the big antenna, but since all the four tube sets at NAA are used experimentally, and the antenna used with the arc set varies with the wavelength employed, all five antennas are used in various combinations. Here, again, now, you see NAA functioning, while doing a man-size routine job, as a great experimental station.

But from the popular point of view the transformations and experiments at Arlington are interesting mainly for the following reasons:

In the first place the Army and the Navy are for the first time consolidating their radio forces on a large scale. This means that the Signal Corps, confronted with the necessity of building a powerful station to serve, as none other could, as the control station of its net, was able, by pooling its interests with the Navy, to save \$50,000 or so by making use of Arlington instead of building a new station.

There's an economy for you and other taxpayers, but the mere matter of saving money is not the big story. This pooling of forces means a lot more. It means that the Army and Navy are pulling together better than ever before in radio; that the provisions by which the Army handles Navy inland business, such as traffic with recruiting stations, and the Navy

handles Army business to distant transports, stations, etc., are working out with real promise; that the Army and Navy have the promise, together, of developing an aircraft net, with NAA as the control station, that will, first by supplementing the Post Office airplane chain, later, conceivably, by coöperative work with it, get vastly better results than ever before. And since the radio work of the Shipping Board is also handled by the Navy, the Shipping Board is also in the picture.

But the important thing is that the strengthening of NAA for other than long-distance work alone means this: That the Government itself anticipates the time when, with the incredibly rapid development of all sorts of private and public utility intermediate broadcasting stations, *one* Federal station can do *all* Federal broadcasting to the public. And that station, if one reads the signs aright, will be NAA.

The Federal squabble in radio, in other words, is settling, and the passing of the pending radio legislation will simplify the station more. For months now, ever since the Radio Conference formulated that legislation, the inter-departmental radio board called into being by Secretary Hoover has been meeting pretty regularly, to discover ways in which to give all Federal Departments their due in radio and to make the most of the situation as it stands. Even as this is written, steps are being taken to allocate to each Federal Bureau such opportunities as it requires for broadcasting via the Navy's Anacostia laboratory station, NOF. And those who know the Navy's plans know that NOF is not long to retain this function—NAA is to have it.

In other words, NAA, so far as the radio public is concerned, is on the eve of becoming the biggest thing on the Federal horizon. Pending that time, the old giant on its hill is being rejuvenated and in large measure re-equipped.

As a pioneer and as a great experimental station, NAA has done its bit and is continuing to do still more; yet two years ago there was serious talk of dismantling it. We have seen how, as a public utility, it has become almost indispensable, with its weather reports and so on.

But that isn't all. The time is coming when even debates in Congress are to be sent out by tube! That's cheaper and better than paper, easier than reading the *Congressional Record*. Will NAA be the station to do it?



# Making Tubes Do Double Duty

How the Priess "Reflex" Circuit Uses the Same Tubes for Radio and Audio Frequency Amplification

By FRANK M. SQUIRE

Chief Engineer, DeForest Radio Telephone & Telegraph Company

CONSIDER for a moment our utter dependence upon the benefits accruing from the invention of the wheel and axle and the appalling, befuddled state in which mankind would be to-day if this invention had not been made. In just such a state would the radio art now rest if it were deprived of the treasure with which it was enriched by Dr. Lee de Forest's invention of the audion.

Electricity is the art and science dealing with the production, the use, and the manifestations of infinitesimally small charged particles known as electrons. We believe that these particles are free to move through certain materials such as metals, which we call conductors, and are capable of a certain limited elastic displacement through other materials, which we call insulators. Although it was long known to scientists that electrons could be made to bound a short distance away from a hot metallic body and would then return to the heated body, that is to say that electrons or electricity could exist freely in space, it remained for De Forest to devise simple means and methods for establishing useful continuous paths for this free space and current and other novel means and methods for its control.

He demonstrated that he could control a powerful stream of electrons in space by a small electric or magnetic force and mould this heavy stream or electric current into exact conformance with his controlling force, the action being not unlike a trigger or valve action. The layman would picture an electric valve as an intricate maze of switches and noisily moving parts, in a brew of magnets and coils of wire. He is generally astounded to find that it is a static device that is physically little more complex than the familiar incandescent lamp. Dr. De Forest coined the name Audion from the Greek derivative meaning "I hear the ions."

The audion consists of an evacuated chamber, usually a glass bulb in which is mounted a filament similar to an incandescent lamp and

from which, when heated, the electrons are emitted into the space. These electrons would bound back upon the filament if it were not for a second metallic body called the plate, which is mounted in the tube and generally shaped to surround the filament. The electrons may be drawn off the filament across the space between the filament and the plate by properly applying a potential difference between them. The electrons fly across the space at a terrific velocity of the order of tens of thousands of miles a second, making our highest velocity bullet a mere sluggard by comparison. The problem of controlling the flight and even stopping these electrons would appear insuperable, and yet it is accomplished by a third element comprising a grill or mesh of fine wires known as the grid, which is supported in the space between the filament and plate and through which the electron stream must pass in going from the filament to the plate.

In this form of audion, Dr. De Forest controls the electron stream or electric current that is set up across the space in the tube merely by applying slight potential differences between the grid and the filament and accomplishes this remarkable action with an apparent absence of inertia. Complete openings and closures of the electric valve have been effected at the rate of hundreds of millions of times a second.

In 1912, John Stone Stone announced that Dr. Lee de Forest had discovered a method of amplifying voice currents, that is to say, had discovered a method of producing a relatively strong voice current exactly conforming with a corresponding weak voice current by means of an action of the audion known as its relay or amplifying action. The audion was immediately applied to telephone lines and clear and distinct telephony resulted from its use.

Radio engineers were stimulated by this announcement and many circuits and arrangements were devised to utilize the De Forest discovery. The most widely advertised of these is the "feed-back" or "ultra-audion" circuit which accomplished in one audion the

amplification that De Forest had previously obtained in a multi-audion or "cascade" amplifier. The ultra-audion had the additional advantage over the cascade amplifier in that it reinforced the radio-frequency currents prior to their rectification and thereby increased the sensitivity or range of the receiver when operating on weak signals. The circuit suffers from the great disadvantages not present in the cascade amplifier, namely, that it is operated at a point of great instability, and in general use sets up the radiation of interfering pulses which interact with the transmitted waves and cause the familiar squeals and whistles that are so annoying to the broadcasting radio audience. These interfering pulses also interact with the transmitted waves to cause a most disagreeable distortion or "mushing" of the received speech or music to the entire locality within the range of the radiating receiver.

Due to the low cost of production and the initial inexperience of the broadcasting public, enormous quantities of the whistling or interference producing types of receivers were placed on the market and absorbed by the public last winter. The worst offender is the single-circuit set of this type designed for use on an open antenna.

The future of broadcasting demands the retirement of all forms of radiating or interfering sets. A constructive programme might be worked out along the lines of the modification in the objectionable types of sets now in the hands of the public by the original manufacturer and a re-design of the present product of the manufacturers whose equipment radiates or interferes in the process of normal adjustment. The addition of a simple device to the existing receivers makes this possible at nominal cost.

The De Forest Company pioneered the broadcasting of music and entertainment as early as 1913 and appreciating that an inevitable Radio Tower of Babel would result from a dense operation of ultra-audion and other varieties of "whistling" receivers, produced for this use only such types of receivers as were strictly non-radiating. In the meantime their research organization was busily occupied in attempting to devise a receiver solution that would combine a great sensitivity and still be free from the production of radiating interference of either the "mush" or "whistle" types. After many disheartening

failures their efforts were realized in their acquisition of rights under the Priess amplifier inventions and the particular embodiment employed by them is in their design of the Priess "reflex" receiver.

This receiver is a three-audion design that possesses a very great sensitivity. It will provide good telephone reception without any form of antenna and merely the tuning coils in the receiver at distances of approximately fifty miles. It will give similar reception from a two-foot coil antenna with which the set is equipped over ranges in excess of 1000 miles. If an open antenna is used with the set, it need merely be a short wire run entirely inside the house from the receiving set to the moulding around the room and thereby completely dispense with lightning switches and the usual elaborate outside rig. An outside antenna may be used if desired without emitting interference. Added to these advantages of extreme sensitivity, the elimination of the outside antenna, the property of directional reception, and freedom from the production of interference, are a superior quality of distortionless reproduction that faithfully records the modulation of the transmitter, a small number of operating adjustments and a pronounced stability.

I am certain that the readers of RADIO BROADCAST will welcome a brief outline of the history of the conception and effort that culminated in the invention of the Priess amplifier system, since this romance has never been made public up to the present time. In April, 1917, with the prospect of war with Germany becoming increasingly apparent, William H. Priess, then a U. S. Radio Inspector attached to the Second District Office, entered the Navy, and thereafter joined the Radio Engineering Design and Research organization at the Washington Navy Yard, at first in the capacity of Radio Electrician and then as Radio Expert Aide. He remained there until he entered the U. S. Army in January, 1918, and sailed overseas. From the skeleton force of April, 1917, comprising Lieut. W. A. Eaton, U. S. N., Radio Expert Aide L. L. Jones, and Priess, the Washington Navy Yard radio organization was built up by hard work and the acquisition of additional talent to the most productive radio research, design, and development organization in this country. They were charged exclusively with the development and design of all radio receiving and amplifying apparatus to be used by the Navy and with the

prosecution of vacuum-tube development and production. In April, 1917, the Navy Department did not possess a receiver or amplifier of its own design, excluding minor modifications of standard apparatus of other manufacturers. The existing receivers in use by the Navy were very poor in selectivity. None of the oscillating forms of receivers would actually oscillate below 800 meters. Amplifiers were not in general use, owing to a lack of the necessary audions and the general unreliability at sea of the types then available. There was a severe shortage of vacuum tubes. No approved aircraft transmitting or receiving equipment was available. Ten months later, due to the untiring efforts of Eaton, Jones, and Priess and the support of others in the Navy Department (notably Commanders Hooper and Le Claire), the entire aspect of the situation had been altered. The Navy was in possession of its own designs of selective receivers for ship, air, and shore application that ranged from 35 meters to 25,000 meters and regenerated all over this range, audions in such quantities that store stocks could be maintained, amplifiers, and many special devices which are confidential naval data. In addition, the ice had been broken on tube transmitter design, and numerous improvements devised for arc transmitter signaling, and certain circuits developed that permitted the simultaneous transmission and reception from a single station.

During the war, all technical minds in Navy service and employ turned for recreation to devising methods for locating and exterminating the undersea peril of the German submarine. Jones evolved a system of submarine detection based upon magnetizing the steel hull of a vessel with an audio-frequency alternating magnetic field, and arranging coils on either side of the field near one of the poles in such manner that when cross-connected with a receiver they balanced out the electromotive forces induced in them. If media of greater permeability than water were introduced on one side of the ship—for example, the iron hull of a submarine—the flux from the ship through the space on that side would be increased and the balance disturbed. Either an orientation of the coils or the ship would give a direction line and a base run establish the location of the hidden menace. The solution was a very ingenious one but not considered by Jones of sufficient range to have warranted its installation.

Priess worked on his pet theory that the



FRANK M. SQUIRE

The author of this article, completed models of the "reflex" receiver last summer and has had excellent results from them in rigorous tests

submarine would, when running under water, emit a complex but regular high-frequency radiation, modulated by some complex but regular low-frequency envelop due to the high-frequency oscillations set up by the sparking of the brushes on the commutator of the electric driving motor and the modulation affected by the regularity of this sparking and the influence of other pulses due to parasitic effects of pole tips, short resonant circuits, and so on. This radiation should be capable of directional reception. Its regularity and characteristics should serve to identify the type and speed of the submarine. He reasoned that the predominating radio frequency would be at the natural period of the submarine hull, and that the predominating audio-frequency modulation would depend on the sparking rate, that is, the speed and number of commutator bars. He concluded that the receiving device would have to be several orders of magnitude more sensitive than existing receivers since the pulse would necessarily be weak and that the investigation should include all frequencies since no German submarines were available to

measure the predominating radiated or modulating frequencies. Benefiting greatly from the tube tuition and experience of Jones, and the open grid circuit audio-frequency amplifier designs of De Forest, he plunged into this problem early in May and by the middle of January, the following year, had evolved many discoveries of new fundamental principles, methods, processes, and apparatus for stable highly efficient amplification of any frequency from the high radio to the low audio frequencies, non-distorted audio-frequency amplification, the control of the breadth of band of an amplifier, certain simple circuits for heating filaments of a receiver or amplifier audion from a line, many designs and principles relating to coupling means between audions to effectuate amplification, and many important amplifier circuits.

Results were netted mainly from methods of attack based upon conceptions of physical actions and reactions in the coupled tubes as not much different from the familiar resonant-coupled circuit solutions evolved in quenched spark-transmitter practice with account taken for the amplifying constant of the tube, its grid and plate circuit characteristics and the capacity couplings between the tube elements. Pries designed and released for production before leaving the Navy several amplifiers, the most widely known being the Type S. E. 1000. The United States Government has prepared and filed a patent application on the Pries amplifier inventions, receiving a license for government use and ceding all title and commercial rights to the inventor.

The "reflex" set of the De Forest Company is known as their Type D7. The author designed it, as a combined three-tube amplifier and receiver. The receiver includes a two-foot coil antenna and tuning condenser system. It has a wavelength range of 250-500 meters with an adequate overlap. The original model of the Type D7 included a primary and secondary coil system to provide reception from an open antenna via the usual two-tuned circuits. In the later models the coupler has been replaced by a vernier condenser although posts are retained for antenna and ground connection to permit the user the same flexible antenna systems and at the same time reduce the number of adjustments in the set. In this form, if an open antenna is used, it is always used in combination with the coil antenna. The received powers of both open and coil antenna are then

additive and both antennas are simultaneously tuned by the same adjustment knob. The coil antenna is a pancake coil of a size usually found in transmitter loading inductances. It operates to receive via the electric and magnetic components of the wave jointly as shown in the coil or directive antenna patents of Lee de Forest and John Stone Stone owned by the De Forest Company and not, as popularly believed, as a receiver solely of the magnetic component of the wave. The latter is a phenomenon of induction and not of radiation.

The received power stored in the tuning condenser is impressed upon the grid circuit of the first tube and is then amplified through each of the three tubes at radio frequency, building up the received signal from an infinitesimal value to a very great amplitude. The signal is then rectified by a galena crystal detector and "reflexed" back and its potential raised through an audio-frequency transformer to the grid circuit of the second tube. It is then further amplified at audio frequency in the third tube and the complete output drawn off the plate circuit of this tube. A control is placed in the grid circuit of the first tube to enable a continuous variation of the grid circuit damping over a range resulting from the grid current losses that follow the change of grid potential from a value of zero to a positive value equal to the potential drop across the filament. This is not a grid "bias" for the purpose of securing rectification or operation on the non-symmetrical portion of the tube characteristic nor an application of grid potential for the purpose of securing operation on the symmetric portion of the tube characteristic as clearly evident from the range of these values and the fact that neither of these effects if present are in any manner useful in the Type D7 circuit. All the remaining grid circuits of the amplifier are tied in permanently at zero potential and are therefore in a condition essential for them to be highly efficient amplifiers.

The type of radio-frequency amplification in the Type D7 is of such form that it provides an enormous sensitivity accompanied by a correspondingly great stability. It is effective over a very wide band. The transformers have an insulation between primary and secondary sufficiently great to safely withstand potential differences of the order of 1500 volts.

Since all detectors have a threshold value,

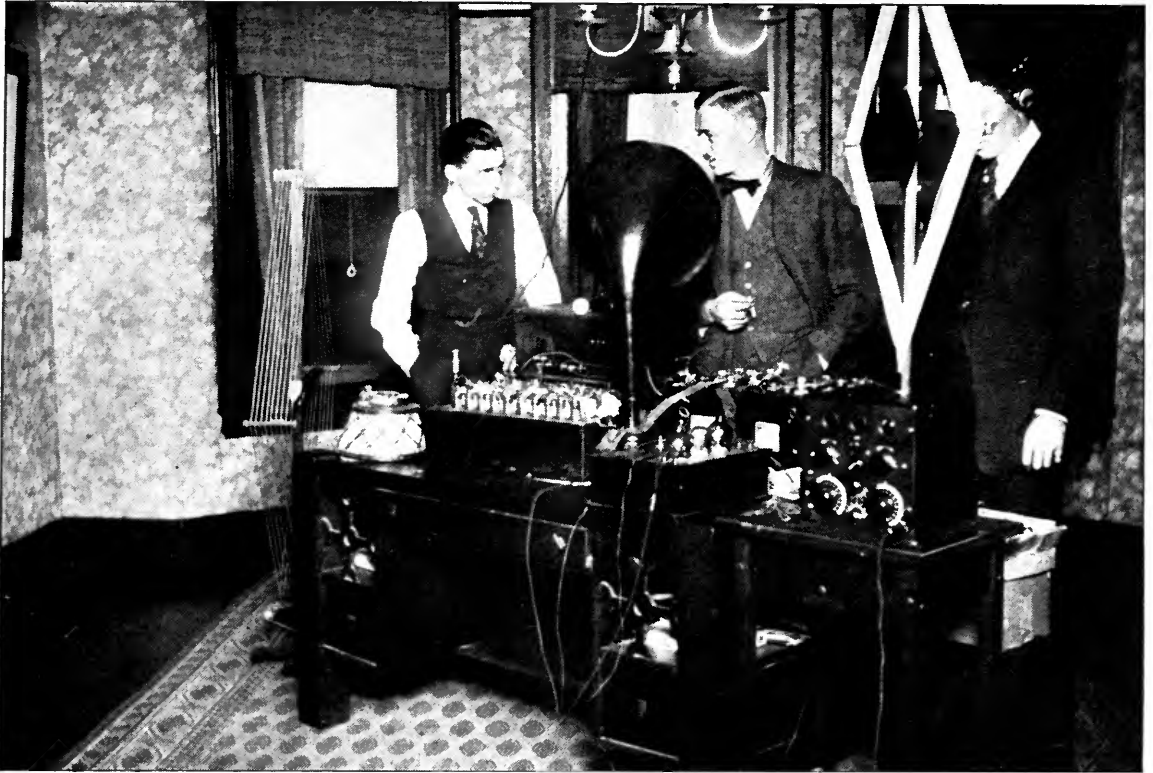

## TRYING OUT THE REFLEX RECEIVER

Left to Right: Arthur H. Lynch, Richard Wagner (whose remarkable no-aerial receiver was described under "How Far Have You Heard?" in the December issue), and Frank M. Squire

that is to say they require a certain appreciable minimum value of radio-frequency amplitude before they are operative, the problem of distant or sensitive reception necessarily requires a system of radio-frequency amplification prior to the detector to attain at least this threshold value. It is an error to evaluate a detector followed by a powerful audio-frequency amplifier as the equivalent of a correspondingly powerful radio-frequency amplifier feeding a detector, for the reception of weak signals. The radio frequency solution is satisfactory; the audio solution is not, for if the threshold value of the detector is not attained, the following audio steps have nothing to amplify; the radio frequency steps start at an infinitesimally lower limit and are effective up to the point of saturation of the detector. In radio-frequency amplification there is no tube or transformer noise and if the correct principles and method are employed in the design there is no distortion. Very high audio-frequency amplification is accompanied by tube noise and, in certain designs, by transformer noise and generally plays

an independent tune of crackles. It is also very susceptible to distortion.

The receiver employs a crystal rather than a tube as a detector. This use of a crystal sensitized by a radio-frequency amplifier between it and the antenna has never been previously applied to commercial sets due to the presence of many difficult problems involving instability and reaction. Radio engineers have for a long time appreciated the inherent value of the solid rectifier in this general use, but it remained for Priest to solve the problems in a balanced adjustment, free design, and attain the inherent benefits accruing from its use. Some of these are: a total absence of parasitic noise at the rectifier which ordinarily occurs in a detector tube and is amplified at audio frequency to a disagreeable amplitude, the relatively greater freedom from distortion of a crystal as compared with a detector tube, the elimination of a number of detector-tube adjustments and the necessity of changing them very materially as the tube ages, and the saving of a tube and the filament and plate

powers required to operate it. In this use of a crystal, all points on the crystal give reception and the adjustment of the contact point merely gives a variation in the received signal. Furthermore, the adjustment will remain fixed for months since it is not effected by static or the factors which are present in the usual crystal circuit. The crystal is both electrically and mechanically cushioned against both types of shock.

In the Pries "reflex" circuit, used in the Type D7, the vacuum tubes are made to perform simultaneously a double duty, first as amplifiers of radio-frequency currents and then as audio-frequency amplifiers without instability or squeals and with each amplification separately efficient. Added to this phenomena there is a certain amount of radio-frequency "reflex" which is accomplished by adding to the combined amplification some of the double-frequency radio frequency generated in the detector circuit and led back via the mutual capacity of the transformer windings and the capacity of the wiring and circuits in the set. "Reflex" is not feed-back or regeneration. In feed-back, changes in plate-circuit potential caused by corresponding grid-circuit potential variations are reimpressed in identical wave form, phase, and frequency upon the grid circuit and they result in additional changes in plate potential, or an amplification. In the phenomena of "reflex" an output circuit which may be a grid circuit or a plate circuit or a circuit coupled to either or both of them is passed through some device which changes any one, two, or all three of the characteristics of the phase, wave form or frequency of the output wave, the resultant—which is usually of a complex form and may even be discontinuous periodically—is then impressed upon a grid or a plate circuit of the tube device which is primarily causing the "unreflexed"

output. Reflex may be at higher frequency than the output frequency and usually a harmonic, or at a lower frequency, or both step up and step down may be simultaneously present.

Several reflexes are possible simultaneously in a tube. In feed-back, factors are present to hold the system in phase. In reflex no such factor is useful in most of the simple forms.

The writer completed models of the Type D7 in August and has since had them under rigorous tests. In one of the tests the set was installed with its coil antenna inside the metal body of a Hupmobile sedan with the intention of determining both the action of the set in dead localities and its daylight range on the Newark, N. J., station. Tests were made every five miles without removing the set from the car. At sixty-five miles from Newark, no appreciable reduction was found in the received signal and this test was abandoned. Good reception was had at all the notoriously "dead" spots on Long Island. The jouncing of the machine did not affect the crystal detector adjustment during these tests. Tests were made with the set installed inside of steel frame buildings in the heart of New York City. Both local and distant reception was very good under these conditions. At his home in Bay Ridge, N. Y., the writer has received practically all of the stations east of the Rockies and north to Buffalo and south to Havana using the coil antenna provided with the set. Good success has also been had by backing up the output of the set with power amplifiers for the entertainment of a group of listeners.

Owing to arrangement with the inventor certain of the methods, principles, processes and apparatus involved in his invention are being maintained as secret, and it is regretted at this time that these details cannot be made public.

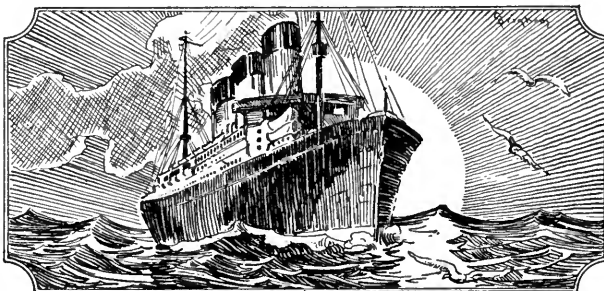
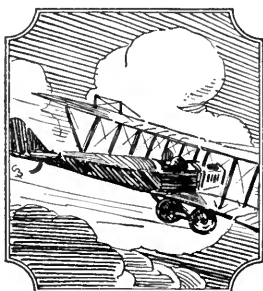

# The "Ham" What Am

By ROBERT F. GOWEN

I AM just beginning to find out why I did not remain in China. I left there sooner than I had planned as I felt I was getting out of touch with radio development at home. Letters from my friends told obscurely of the remarkable inventions that had taken place in the short nine months of my absence; of how broadcasting had revolutionized both transmission and reception and that I would have to begin all over again and learn the new game of 1922. But the temptations to stay were many. I had learned to like the Chinese people with whom I was doing business and they in turn almost refused to let me go. They insisted that I should stay with them for another year at least, working out their radio problems which, though difficult, were intensely fascinating. I felt I could not afford to get behind the times. And now I am just awakening to the fact that it was not being out of touch with the new development that was worrying me but that I was hankering to get back to my old amateur set and into the game again as a "Ham," which, after all, gives us more pleasure than the professional phase of radio.

And what did I find on my return? Listening in on 200 meters brought back the old thrill that one gets when he is able to copy a little code after a long struggle as an amateur to learn it and to send it out with a home-made transmitting set made up of miscellaneous junk parts at a minimum of expense. There were a few of the oldtime buzz-saw rotaries asking each other "QRK" and "QRU" with the usual "MSG," etc., tacked on. I noticed an increase in the number of CW and ICW sets though the traffic was pretty light, it being the off season when the static was bad. I tuned to 360 meters and heard a babel of phonographs sending out the inevitable jazz just as I and many others had done some two years previously.

I began to look for the new developments, and beyond the Armstrong super-regenerative circuit, the value of which seems to be somewhat questionable in its present state of development, I am still looking for them. In other words the stunts which we, as amateurs, had tried out and discarded as worthless have now been commercialized to be inflicted upon the

unsuspecting public. I had heard that some wonderful thing had been brought out by which you might use the electric wiring in your home as an antenna and thus do away with expensive outside aerials forever. I found it to be nothing but a condenser such as we used in attempts to employ electric light wiring and telephone lines as aerials in the old days, the only difference being that the condenser was now moulded into a plug form that would screw into the ordinary electric light socket. The results obtained with it were identical with those we used to obtain, i.e., practically negative. So now I am not quite so worried about being behind the times except in one respect and that is that I find that practically all my old amateur pals have also been commercialized and are now operating broadcasting stations or acting as chief engineers for the thousands of radio manufacturing companies that have sprung up during the past year.

Broadcasting progressed as the public got tired of "canned" music. The Government was forced to allot a 400-meter wave to super-broadcasting stations which were not allowed to transmit music of the "canned" variety and were therefore compelled to send out something worth while. This was excellent and a great step in advance. And then what happened? The public who were beginning to enjoy broadcasting were beginning to hear strange things with the many cheap, single-circuit tuners that the thousands of illegitimate, so-called "radio-manufacturers" forced upon them. These strange numbers which were not on the programme consisted of dots and dashes which interfered with the listeners' enjoyment of the music, and Mr. Public, having read in the papers that the country was infested with amateurs immediately said to himself, "Why, that is an amateur next door bothering us and he has no right to play with his apparatus when we want to hear this music that is so worth while!"

And so to-day, the "Radio Fan" as he is popularly known, is attempting to bring legislation to squash the amateur and put him out of business on the ground that he is a nuisance and is merely playing with a toy that bothers other people. But Mr. Public does not stop to real-



“THE HUB OF THE RADIO UNIVERSE”

Mr. R. H. G. Matthews, known to hams as “Maaty,” is here shown operating the “hub,” which is so-called because, located in Chicago, it is a clearing house for amateur messages in all directions

ize that if this is true perhaps he too is playing with a toy for his own amusement. He does not understand or appreciate what “wavelength” means. He does not even know what kind of a circuit he is using for reception and that if he used a different type of circuit, perhaps a little more expensive or perhaps even cheaper (if bought with more intelligence), he would not hear the dots and dashes when he wanted to hear music. He does not know that if he had the proper type of receiver and knew how to tune it he could hear either dots and dashes or music at will, one without interfering in the least with the other. And the problem is, how are we going to educate him to these facts so that he may play at the same time that the amateur is playing?

But does the amateur play, and what is a “ham” anyway? Perhaps not ten per cent. of the readers of this article know the proper definition of the word “ham.” And yet it is very simple. A “ham” is not a small boy

using a spark-coil, jamming up the ether with noises sounding like a boiler factory in action, but a young man of the average age of twenty years who has enthusiastically studied radio both theoretically and practically and whose idea is to better the art in any way he can by unselfish application. He has solved many problems that have confronted him, not for financial gain, but for the love of the thing. The very apparatus that you are using to-day, as well as the equipment that is sending its music to you, is the result of his effort and conscientious endeavor. The man who announces at a broadcasting station is a “ham.” The man who operates the broadcasting transmitter is a “ham,” and the man who designs your receiving set is a “ham.” Why? Because no one but a “ham” can do these things. When I was chief engineer for the De Forest Company, designing among other things radio telephone transmitters, purchasers would ask me to get them men to operate the equipment that they



bought. Do you suppose I could get a commercial operator to operate a radio telephone set? No. I found they knew absolutely nothing about it and in every case I had to get a "ham", simply because the former was a man who knew only how to press the key and read code while the latter was a technician who had trained himself in the fundamentals of radio and knew how to analyze the circuit and keep it functioning properly in addition to his knowledge of key pressing. Likewise, every man I had in my laboratory was an amateur, not because I was one but purely because they were the only men obtainable who could tackle the problems placed before them. The question naturally arises, "Why does the amateur have such enthusiasm and why does he not lose interest after a while?" The answer is "sportsmanship." This sportsmanship is the finest type we know of, as it is dependent for its existence on personal unselfishness in not interfering with the other fellow; a sportsmanship that breeds good fellowship. Then there is the mystery and thrill of it and the tremendous

incentive to beat the other fellow's record. And some of these records are hard to beat. Fellows on the Pacific coast and some as far east as Minnesota "work" an amateur in Hawaii nightly. Figure the distance for yourself and remember that these stations are restricted to an output of 1 kw. of power and usually employ less than this amount. And this with home-made apparatus!

Everyone knows of Frank Conrad, assistant chief engineer of the Westinghouse Electric and Manufacturing Company, and Paul Godley, who went to Scotland to listen for the transatlantic tests of the amateurs. These men are "hams" through and through, always were and always will be, and there are hundreds of professionals just like them though they are not so well known. Did you ever hear of Mr. H. P. Maxim, President of the American Radio Relay League and his fine station that does remarkable things at Hartford, Conn.? Then there are Irving Vermilya at Marion, Mass., "Johnny" Clayton at Little Rock, Ark., J. A. Gjelhaug at Baudette, Minn., A. L. Groves at

(BELOW) 9QK, A PRE-WAR STATION

Built and operated by John  
A. Gjelhaug, Baudette, Minn.

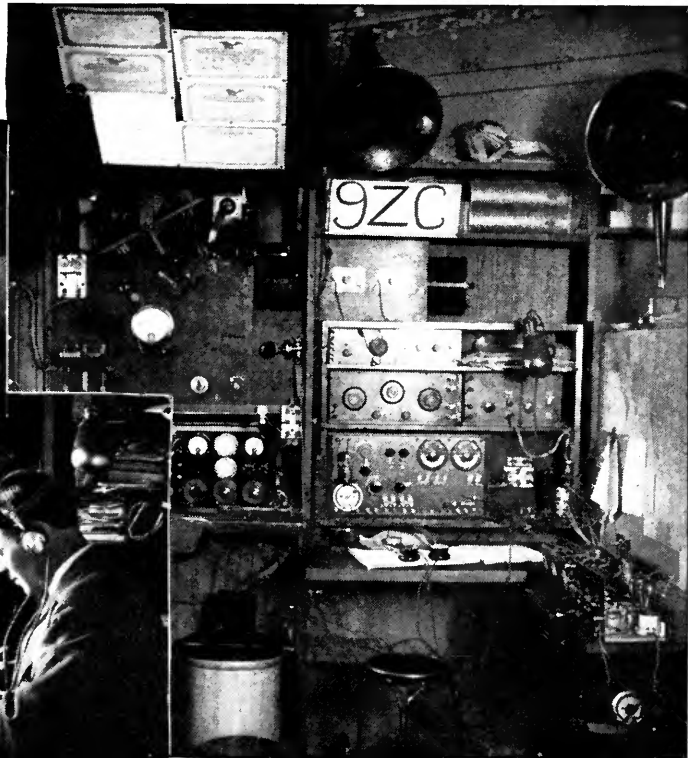

(ABOVE) MR. GJELHAUG'S NEW STATION

Located in Baudette, Minn. This picture was taken November 27, 1922

Brooke, Va., C. R. Runyon at Yonkers, New York, Mr. and Mrs. Charles Candler at St. Mary's, Ohio, and a host of others too numerous to mention, all known from coast to coast for their untiring enthusiasm in American amateur radio. There is the ever popular "Matty"—R. H. G. Matthews of Chicago, one of the best known "hams" in the game. And yet he never did anything very startling. He is not of the fireworks type. But he runs a station, 9ZN, that has been called "The Hub of the Amateur Universe" because it can be absolutely depended upon to relay messages north, east, south and west, a thousand miles or more any night without fail. It has been built and rebuilt by Matthews and his assistant operators to a remarkable state of efficiency which every true sport is bound to admire. Then too "Matty" is the manager of the Central Division of the A.R.R.L.

A.R.R.L., the American Radio Relay League, is an organization of thousands of these amateurs, conducted by and for amateurs. It came into existence in the old days after the ama-

teurs in the East awoke to the fact that there were a lot of them located all over the country. The thing that awakened them was the Federal Radio Law of August 13, 1912. Among other things which this law provided was a call book and this book contained the names and addresses as well as the call letters of all the amateurs who had passed the necessary tests to secure transmitting licenses. The book disclosed the astounding fact that there were several hundred of them scattered over the various States of the Union. It demonstrated immediately that it was a good thing to observe the law and take out a transmitting license because it established one's standing and gave one a dignified position among the better amateurs of the country. With it came the birth of the radio club. It came from the natural tendency to gather together and exchange experiences, information and knowledge. In this way the radio club became the meeting ground of the amateurs and presently there came into being a wonderful spirit of fraternity. One felt a queer little thrill at these early radio club meet-



THE AERIAL IS OUT OF THE WAY UNDER THE TOP

With this portable set, Mr. Gjelhaug has heard long-wave arc stations hundreds of miles away with a single tube. While the car was making twenty-five miles an hour, he has copied signals from a spark-coil transmitter using 12 watts input, up to five miles

ings when he came face to face with the fellow he knew well in the air but whom he had never seen. To one who has never sat in his little back room late at night and conversed with another fellow seated in *his* little back room away over in some remote town, and then finally come to grasp the hand of this fellow, can never come this peculiar thrill.

The radio club was the natural birthplace of the relay. It probably developed in the minds of several of the clubs at about the same time, but it was in the Radio Club of Hartford, Conn., that the relay idea which finally became the American Radio Relay League first took practical form. It was born of the fact that one amateur in Hartford found he could communicate with another amateur in Windsor Locks, 25 miles away. If Hartford could reach Windsor Locks which was half way to Springfield, why could not Windsor Locks reach Springfield? And if this could be done why would it not be

possible to branch out and to eventually link up with amateurs in distant parts of the country? The idea was an incentive for the amateur to study and work harder and to improve his apparatus to cover great distances, to simplify it and to make it more practical.

Just look at the result! To-day the whole United States is divided into operating districts, each supervised by a competent and enthusiastic amateur who is responsible for the traffic in and through his district. He appoints amateurs to take care of traffic along certain lines so that now there are trunk lines from one end of the United States to the other, North, East, South, and West by means of which messages may be sent to any point in the United States. The organization is so perfect that substitute stations and even alternate

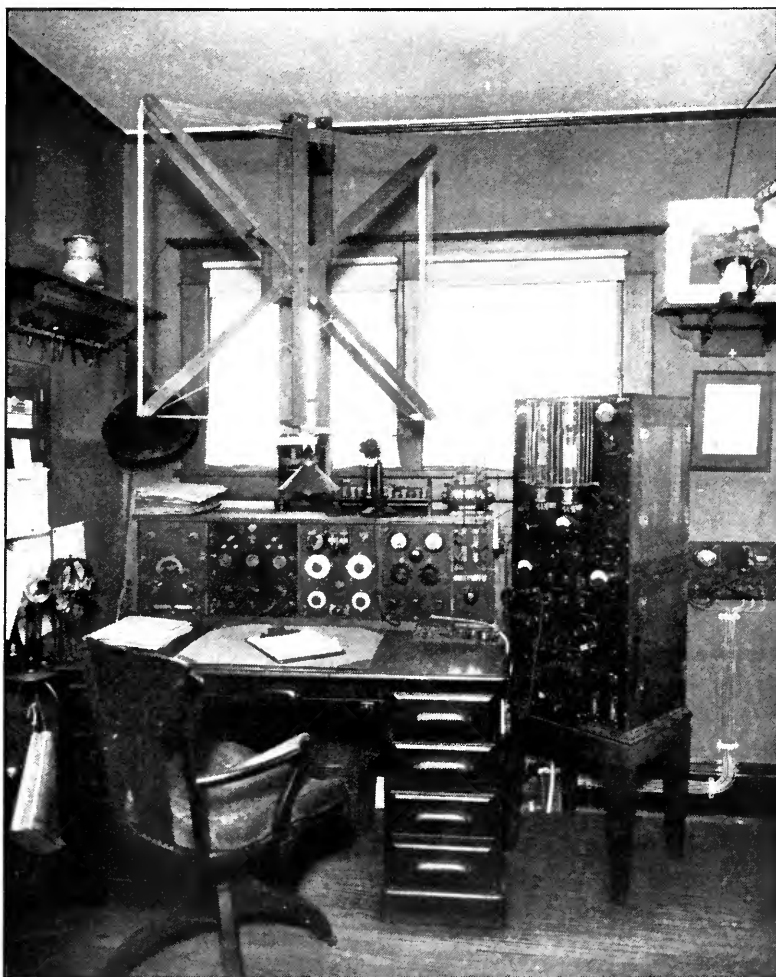

MR. GOWEN'S STATION IN OSSINING, N. Y.

The tube transmitter, mounted on the upright panel at the right, is used for broadcasting and has been heard all over the country

lines are established to handle a message should an amateur on a regular trunk line be out of commission for any reason. Monthly reports of the traffic are made by the Division Manager to the Traffic Manager at the headquarters in Hartford, Conn., and these are published in the official organ of the League, a truly remarkable magazine known as "QST." The nominal dues of the association go to pay the expenses of publishing this magazine which is no small matter and requires to-day a rather large office force.

What have the amateurs accomplished by such organization? To begin with they have maintained their very existence by it for attempts have been made from time to time to legislate against them. By appointment of the present vice-president, Charles H. Stewart,

as chairman of the Legislation Committee of the Association, it has been strongly represented at all hearings of radio bills in Washington with the result that bills detrimental to the interest of amateur radio have been tabled. Such representation has been of vital importance and the amateurs are now called in for consultation on important matters of radio policy so that Mr. Stewart and others were present at the Radio Telephone Conference called by Secretary Hoover last Spring.

The record of war needs no telling. These young amateurs to the number of nearly five thousand gave to Uncle Sam in his Army and Navy the best radio operators the world has seen. It is no reflection upon the Navy or Army operator to say that the amateur beat him at his own job. The amateur had developed his extreme expertness because of his love for his hobby, and he represented furthermore the pick of the young men of the country. No matter where one went in the Army or in the Navy during the war one encountered the amateur on every hand, from the high officer to the enlisted man. The chief operators in all of the important stations were ex-amateurs. When President Wilson journeyed to France

and back, the chief radio operators on the *George Washington* were ex-amateurs.

And now all of these young men are amateurs again, and in these days of peace, they have rebuilt their organization. Their recent accomplishments are a good indication of what they are and what we may expect of them in the future. Over a year ago they decided to demonstrate what their organization could do in the way of a rapid interchange of messages from the Atlantic to the Pacific and back, and from the Canadian border to the Gulf of Mexico and back. A series of messages was started from Portland, Maine, Boston, Mass., Hartford, Conn., New York, and Chicago, and destined for points on the Pacific Coast and on the Gulf of Mexico. Each of these messages had to be relayed through several stations, the message delivered, the answer secured, and this answer transmitted back to the starting point. A Portland, Maine, organization sent a message to a Portland, Oregon, station, and received its answer back within an hour. Similar messages went from the various points mentioned. One message originated in Hartford, Conn., and was addressed to one of the amateurs in Los Angeles, Calif. From the time that this mes-

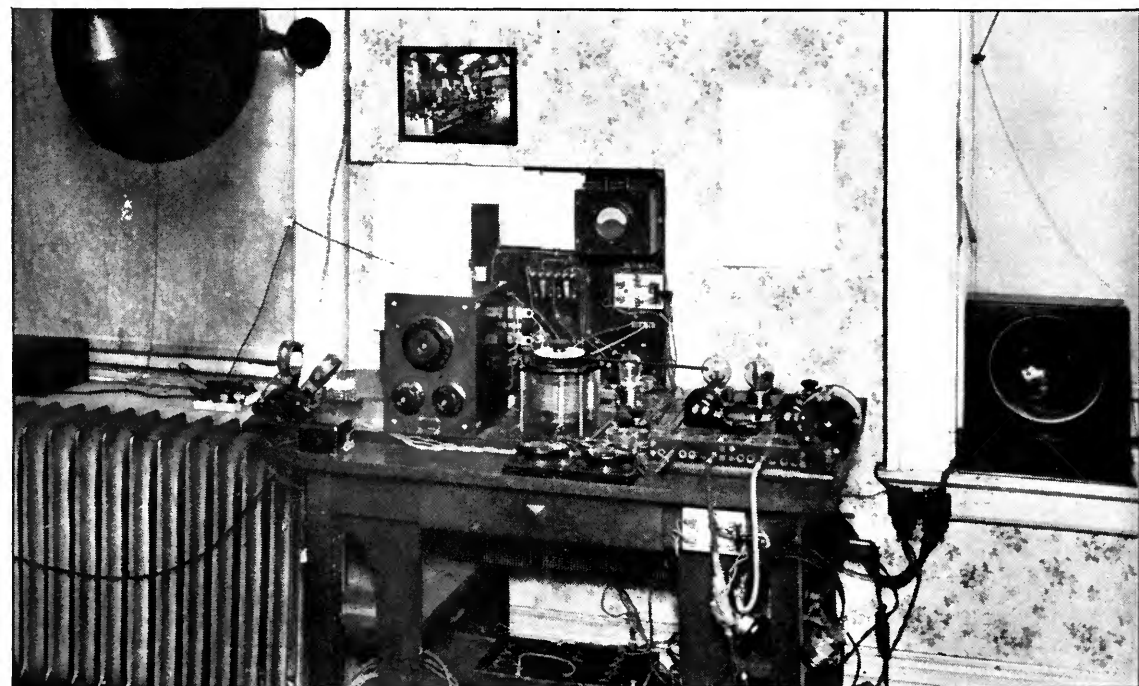

SOME BROADCAST ENTHUSIASTS PROCURE ELABORATE APPARATUS

For the purpose of getting the distant stations. In a receiver of this type there are entirely too many adjustments for the "ham" to bother with, especially where rapid DX (long distance relay) work is carried on

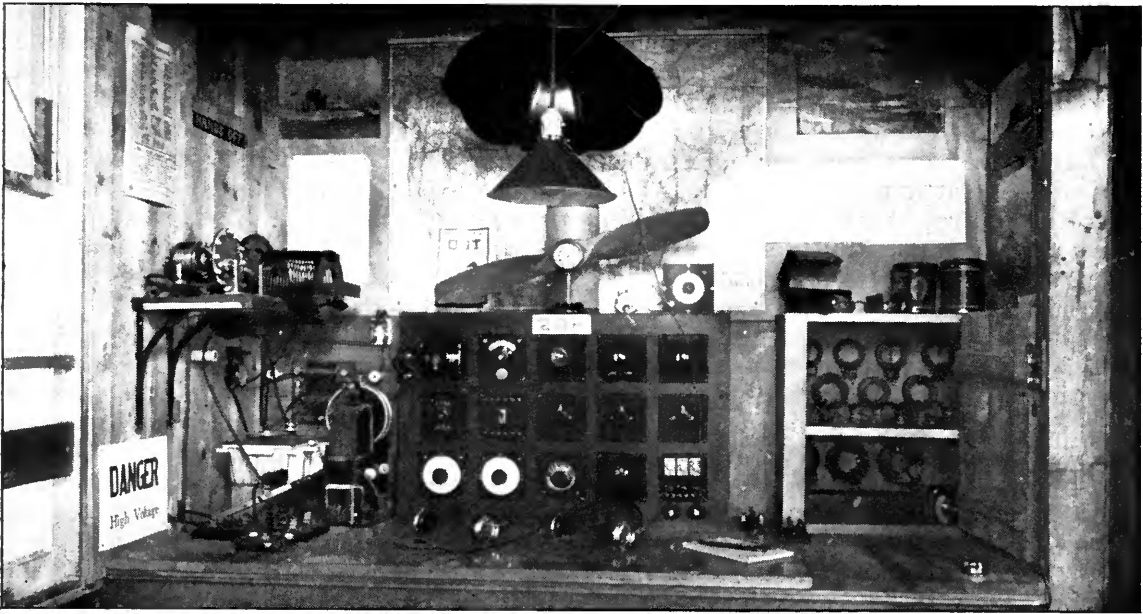

THE STATION OF HAROLD ROBINSON AT KEYPORT, N. J.

When built, the transmitting apparatus of 2QR was of better design than that employed on most commercial vessels. However, spark transmitters are rapidly going into the discard in favor of the continuous wave system. The tube transmitter which supplanted the one shown at the left in this picture was heard in Aberdeen, Scotland

sage started its first dot at the key in Hartford to the time the answer was received back from Los Angeles and all written out on a telegraph blank was just *six and one half minutes*. This message was relayed at Chicago and Roswell, New Mexico, and the *esprit de corps* was such that the entire country full of amateurs remained quiet during the interval of the tests so that every assistance might be given to a quick transit.

Within the past year it was decided the technical advance in Amateur Radio and the advance in organization had been such that the greatest of all feats might be attempted. This was to span the Atlantic Ocean by amateur wireless and establish communication between the amateurs of America and those of Great Britain. These young men selected one of their number, Mr. Paul Godley, to go to Europe and look after the reception and encourage the English amateurs to take an interest in the matter. All the expenses were borne by the amateur organization. The result of the transatlantic tests are a classic in radio history, for more than thirty American amateur stations were recorded in the British Isles. On November 22nd last, all records were smashed to atoms when 1 AW at Hartford, Conn., sent a message to 6 ZAC in Hawaii via 9 AWM at

Sleepy Eye, Minn., and the answer returned in just *four minutes and eighteen seconds*. 9 AWM was the only intermediate station! There is no telling where these young men will carry American amateur radio and it is very safe to assume that it will not be long before they will be exchanging messages regularly with their brothers across the seas.

In addition to their own interests in intercourse among themselves they have been of material benefit to radio in general because "Necessity is the mother of invention" and, having but little to work with, they have been forced to find a cheaper and better way out of their difficulties. In 1920, as an organization, the amateurs of this country collected data for the Bureau of Standards which was not obtainable from any other source in the world. Night after night the "hams" sat up and made fading tests on signals sent out from several selected stations in the hope that the data collected would give some insight into the cause of fading as a basis on which to combat it. An analysis of the results obtained, however, showed little of value at the time, but it is believed that later when we know more about the peculiarities of the ether this data will be of inestimable value in overcoming this or similar problems.

The amateurs have checked and rechecked test after test at the request of the broadcast operators and it is safe to say that without the amateurs, broadcasting would never have developed to its present state of efficiency in so short a time. In fact, broadcasting could not have existed without the amateur for he is responsible for the education of the public in the use of receiving apparatus, by inviting his friends to hear the music at his own set. Broadcasting is impossible without an audience and without the amateurs there would have been no audience.

Is it possible, then, that men who know as much about radio as outlined above; men who have designed, constructed and operated the broadcasting stations; men who are conscientiously fair to their brothers in handling traffic and in interference questions; men whose activities have been used many times by an ignorant press as an excuse to cover up some shortcoming of the radio service which has been due to other causes; men who know fully and appreciate the limitations of radio communication and who have therefore unselfishly and without restraint of law agreed to stop transmitting between the hours of 7 and 10.30 P. M. to make certain the enjoyment of broadcast listeners—is it possible that these men maliciously interfere with the work of broadcasting stations on a wavelength removed from that allotted to

them by law? Why should they deliberately wish to go out of their sphere of communication and trespass upon the rights of others, especially since the advent of the Armstrong, Super-regenerative Circuit tends to make for transmission on wavelengths less than 200 meters.

The amateurs have no axe to grind even though in all fairness it must be said that the broadcasting stations, because of their high power output and improper tuning in some instances, do bother them. All they want is to be let alone that they may go forward and develop in years to come with the same remarkable advance as formerly. They agree, as we all agree, that there is a place for broadcasting—a most important place—with its Philharmonic and Symphony Concerts, its Grand Opera and its sporting events as amusement, together with its stock market and weather reports of inestimable value to the public in general. It is fast becoming a public utility that cannot be dispensed with. But American amateur radio must also exist, for of it broadcasting was born and without it broadcasting cannot continue to develop to the unforeseen heights to which we are sure it will climb. There are places for both amateur radio and radio broadcasting, and the solution of the clash between them is a mutual understanding of each other's rights.

## Proper Radio Legislation is Urgently Needed

By S. W. STRATTON

Chairman of the Committee Appointed by Secretary Hoover to Study Radio Regulation as Discussed at the Washington Conference, and Chairman of the Inter-Department Radio Board

**T**HE fullest utilization of radio implies, of course, better understanding of the laws and principles concerned and the improvement of apparatus for sending and receiving. But such existing problems as that of static interference, and the need of increasing the selective power of receiving sets in general use, only serve to emphasize rather than to diminish the need for such relief legislation as that formulated by the Radio Conference. In the present situation there is no substitute for that legislation.

It is clearly necessary to readjust the allocation of the wavelengths that are practicable for broadcasting. Within the limitations estab-

lished by the law of 1912, the inter-departmental board called together by Secretary Hoover has sought, in coöperation with the Bureau of Navigation, to facilitate the largest possible use of available wavebands. What is clearly needed, however, is the removal of many of the present legal restrictions so far as that is practicable. The bills now before Congress do not fix the details but give the Secretary of Commerce authority by which to make and to enforce such adjustments as conditions warrant and progress requires. Such authority, based on general terms, is particularly needed in a situation which changes rapidly and has so large a promise of usefulness as radio affords.

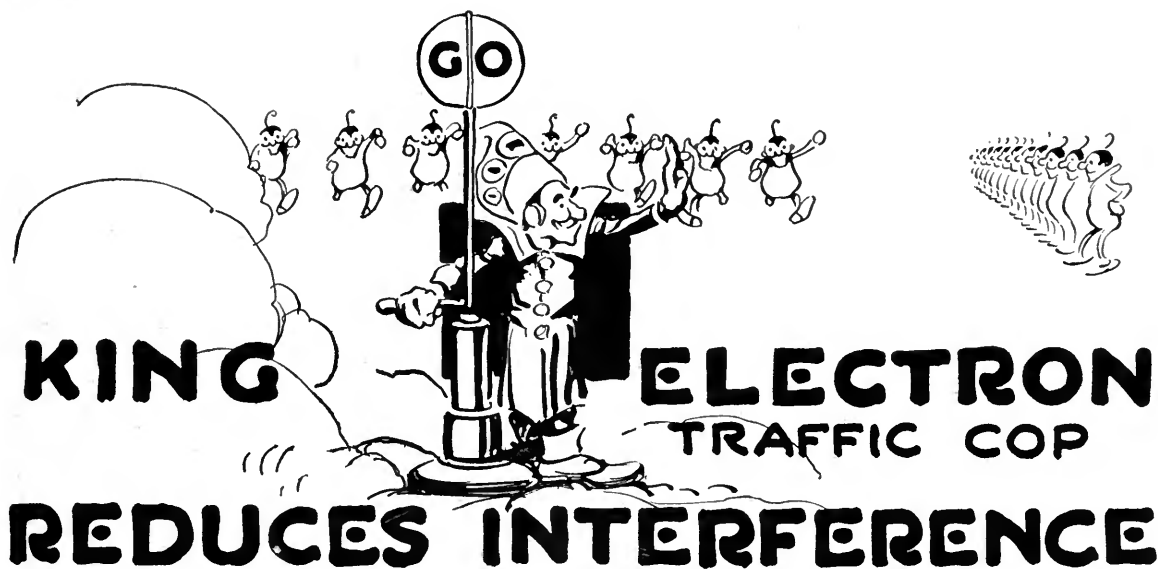

Preventing Confusion Along the Ether Highways. What to Do with the Road Hogs and How Not to Be One

By R. H. RANGER

Engineer, Radio Corporation of America

Illustrated by TOM MONROE

*The traffic down Main Street of a Saturday afternoon is nothing compared to the electron congestion down the aerials of the million receiving sets all over the continent. Federal, commercial, and amateur interests are doing effective work in establishing traffic rules and schedules; and each set owner can assist in making this ether highway of the greatest possible service to the country; first, by seeing to it that he is not interfering with other listeners by radiating energy from a too "tightly" coupled "feed-back," and second, by making his own equipment as free from interference as possible.*

**I**NTERFERENCE of all kinds—electric power lines, motors, X-ray machines, and worst of all, interference between radio transmitters themselves—is now the bug-bear of the listener-in. It is no longer a question of not hearing enough, but rather of hearing too much!

First, the non-radio sources of interference. If the disturbance comes in as a soft humming sound, the trouble is most apt to be in the insulation from the ground or building to the set, the batteries, or the aerial wire. This interference is not of a wave variety at all, but comes in by direct conduction of the electricity from a lighting or power source.

If it is on the aerial, disconnecting the receiving set from the aerial with the set still on will produce silence. With the trouble lo-

calized in the antenna, the antenna should be looked over carefully to see where it comes nearest to any such power source. This is apt to be inside the building. To determine if it is, reconnect the aerial to the set and disconnect the outside portion of the aerial where it enters the building. If the noise still continues, the leak is evidently between the outside connection and the set.

All radio wires should be kept as far as possible away from lighting wires. If it is necessary to cross lighting wires, as great an air gap should be maintained as possible between the two, and insulators should support the radio wires as well as the lighting wires. "Loom" or porcelain tube insulation should cover the radio wires where they cross power wires. This "loom" is flexible insulating tubing.

The storage battery and dry batteries connected to a radio set are distinctly in the radio circuits so they should be well insulated from any possible extraneous currents. If the battery is kept dry on the bottom, no difficulty will be experienced. This will be the case if the battery is kept off the floor with two small pieces of hardwood, or preferably with four insulators. These insulators may be screwed to a piece of board slightly larger than the bottom of the battery, which acts as a stand.

*Motors.* These are the next most common source of outside interference. Naturally, one of the simplest answers to any of these disturbances is to keep as far away from them as possible. However, such interference can be greatly reduced and even completely eliminated, with care. The first thing to do is to determine what motor is at fault. This will be done of course by observing when the trouble is caused, and determining what motor goes on at that time. The same effect which makes a motor cause interference is most apt to be detrimental to the motor itself, so little difficulty should be experienced in getting the owner of such a motor to assist in remedying the trouble. The faulty motor will be found to be sparking badly. This indicates bad "commutator" adjustment on the motor or even worse, perhaps a burned out section. If allowed to continue, this will greatly injure the motor.

There are other methods of reducing interference from such causes such as placing electric condensers across the wire connections to the motor. This involves expense and careful testing, however, and if disturbances continue from such causes, it is better to move your

station, if possible. A removal of some fifty feet may make a great difference.

*Noisy Grounds.* The ground wire may be picking up a great deal of interference. The method of determining this is of course the same trial of connecting and disconnecting the ground wire from the set. If the ground wire does bring in noise, try a different type of ground. If a water pipe has been used, try

the radiator which should be good in the winter with the steam in it, or try a ground rod driven directly into the soil. A small fixed condenser of say .001 microfarad, placed between the ground wire and the ground binding post of the set is quite effective in keeping out power-line or street-car noises while it still lets through the radio signals readily.

Those who have ground space available will find a "counterpoise" of great value, both from the point of view of absolutely eliminating ground disturbances and also in increasing the selectivity or ability of the set to tune sharply to desired signals. Such a counterpoise consists

virtually of a second aerial of three or four wires spaced some six feet apart and running parallel to and under the antenna. Preferably they should be kept off the ground by insulators, the same as the aerial; but weather-proof wires laid on the ground will give quite satisfactory results.

The set, with no ground or aerial connected, should be perfectly quiet. To obtain this condition in a commercial marine receiving station where very long distance work is accomplished, extreme quietness has been obtained by shielding the sets completely in copper-lined iron boxes—batteries and all. This is more feasible of course when dry-

The following paragraphs came to us a few days ago from Mr. Robert Brock, of Wallace, Idaho, and express vividly the great value of radio as a companion to those in lonely places.—THE EDITOR.

This is written from a lonesome eagle's nest in the heart of the Coeur d'Alene National Forest. The spot is the Sunset Fire Lookout Station. I have been up here since June 15th, seeing practically no one in all that time—yet I am not alone. My radio outfit is the best company I could have.

Every night I hear concerts from Los Altos, San Francisco, and Sunnyvale, California, Portland, Oregon, and Seattle, Washington. Beside the concerts, I hear the telephone conversations between Los Angeles and Santa Catalina Island, and every noon the time signals from San Diego. Using my large honeycomb coils, the world's news is at my finger tips.

It is hard to realize the great value of radio to a man isolated as I am. It is indeed wonderful to hear so clearly music played five hundred or a thousand miles away. It was a lucky thought that I had when I brought my set along with me. It is the most valuable part of my equipment.



battery tube sets are used. The radio connoisseur will find his time well repaid in building such a wooden box lined with roofing tin or with copper, with lined front doors to the box as well, so that the set may be closed in completely for the last word in refinement. Even the loud-speaker may be kept within the box to advantage, with a screened opening to let out the sound.

*X-Ray Machines.* There is no known remedy for removing the interference from an X-Ray machine except getting far enough away from it, or shielding the machine itself.

*Smoke Precipitators.* A bad cause of interference is a high-voltage smoke stack equipment. The difficulty is greatly reduced if the owners can be persuaded to shield the high-voltage lead to the smoke stack with a grounded metal screen. This also acts as a safety screen in the factory, so it will serve two purposes.

*Interference Check.* Before deciding that interference comes from any outside source, it is well to check up with someone else in the vicinity to see if he is experiencing similar difficulties. It is well to remember too, that few of the broadcast transmitters can yet give 100% continuous service and quality.

*Radio Interference.* Wavelength interference is by far the most common source of trouble on cool winter nights when long ranges are possible. The first steps will be the same as those already given, a perfectly quiet set with no ground and no aerial.

*Short Aerials.* The first and perhaps simplest method of reducing interference between stations of various wavelengths is to shorten the aerial wire. During the winter months, an antenna fifty to seventy-five feet long will give plenty of received energy to the set. With such a short aerial, the tuning in the set will be greatly improved. With a long aerial, the tuner cannot change the wavelength of the complete circuit of aerial, tuner, and ground very much. The tail cannot wag the dog, in other words. With the short aerial, the tuning is largely in the tuner and much greater selection is possible. Some radio fans will like to have two antennas, a short one to get selectivity, and a long one to get the weaker signals when local stations do not interfere.

*Loose Coupling.* Most of the tuners are of the single-circuit variety. Double-circuit tu-

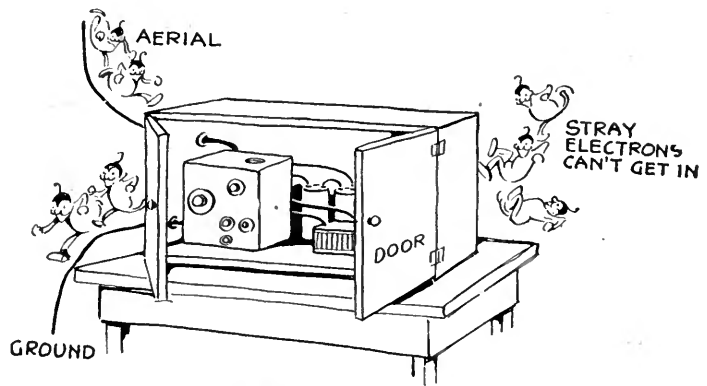

A METAL-LINED BOX

In which the entire set is housed, is of considerable help in keeping out stray electrons

ners are somewhat more difficult to adjust, but permit very much better tuning. As a matter of fact, loose coupling may be accomplished with single-circuit tuners. The shortened aerial is a step in this direction.

To carry the idea further, disconnect the single-circuit tuner from the aerial and ground completely. The aerial and ground are then connected to the two ends of a simple twenty-five to fifty-turn coil. This coil may be of any standard design for radio purposes such as the basket-wound coils or the cobweb type. This coil is then placed near the tuning coil of the single-circuit tuner, say on the cover of the box. The aerial or antenna and "ground" binding posts of the tuner are connected together by a short piece of wire. Or, if another small coil is connected between these same two binding posts, and the first extra aerial coil brought near this second one, the second will pick up the energy from the first, and with the receiver actually loose coupled it will be found by trial that the tuning will be much sharper. As skill is obtained in the adjustments, it will be found possible to have the extra aerial coil quite a distance from the tuner coil.

To make this arrangement a complete double-circuit tuner, it is now only necessary to add a variable condenser between the first extra aerial coil and the ground. The variable condenser should have a maximum value of about .0005 microfarads. This will make it possible to tune the aerial-coil-condenser-ground circuit to the desired signals, and constitutes the "primary" circuit; and the single-circuit tuner which now picks up the energy is the "secondary" circuit of the combination. By varying the position of the extra coils the "coupling" is adjusted.

In place of the extra aerial coil and condenser, another single-circuit tuner may well be used. By this arrangement, one tuner is connected to the antenna and ground, and its detector and any other attachments are completely disconnected. This extra tuner is then brought close to the second tuner which has no direct antenna or ground connection but has its antenna and ground binding posts connected together as explained before and will act on its regular detector and telephone receivers. By adjusting the two sets, the desired signals may be picked up, and as the two sets are moved farther and farther apart, the sharpening of the tuning will be greatly increased although there will also be a diminishing of the strength of the signals. Any two tuners may be used for this double arrangement. Most fans have a simple set with which they started operations which may well be used for the first, and their amplifier set will do very nicely for the second. The simple tuner consists of nothing but a coil and a condenser in series with the antenna and the ground.

Such double-tuning arrangements are best applied to tube sets in which the amplifier tubes make up for the loss in signal energy.

Sharp tuning is by all odds the best means for reducing interference of all kinds. Good ground connections, good insulation of the aerial, and good wire conductors at all points help the sharpness of this tuning. Regeneration also sharpens the tuning, particularly in high-resistance circuits.

*Loop Receivers.* As a further means of reducing interference, there is the loop aerial. The signals which are coming in a direction in a plane with that of the loop—that is, “end on,” not “broadside”—will be the loudest. This is because the oncoming waves will create electromagnetic charges of slightly different potential in each side of the loop, and the amplifier is used to make the most of these differences. Almost any form of loop will give results. Six turns of wire around a yard-square frame will be about right for broadcast reception. The tuning of such a loop is accomplished by means of a single condenser placed across the two wire terminals of the six turns. This condenser should have a maximum value of about .0005 microfarads. The same two terminals which connect to the condenser are also connected directly to the tube set.

Naturally, the loop cannot be expected to collect much energy. As a result, a loop receiver will not be of much value except on an amplifier set. And radio-frequency amplification is in order.

*Radio-frequency amplification.* The experimenter who has conquered ordinary audio amplification, may well try radio-frequency amplification. The circuits are exactly the same except that a special radio-frequency transformer must be used.

For radio-frequency amplification, the electrons have to shoot back and forth at very high rates of change in the tubes. And the capacity of the tube to hold the electrons on its surfaces, regardless of the ordinary action of the electrons out from the filament, has a very important effect on the amplification. If the electrons can rush in and out of the tube easily,

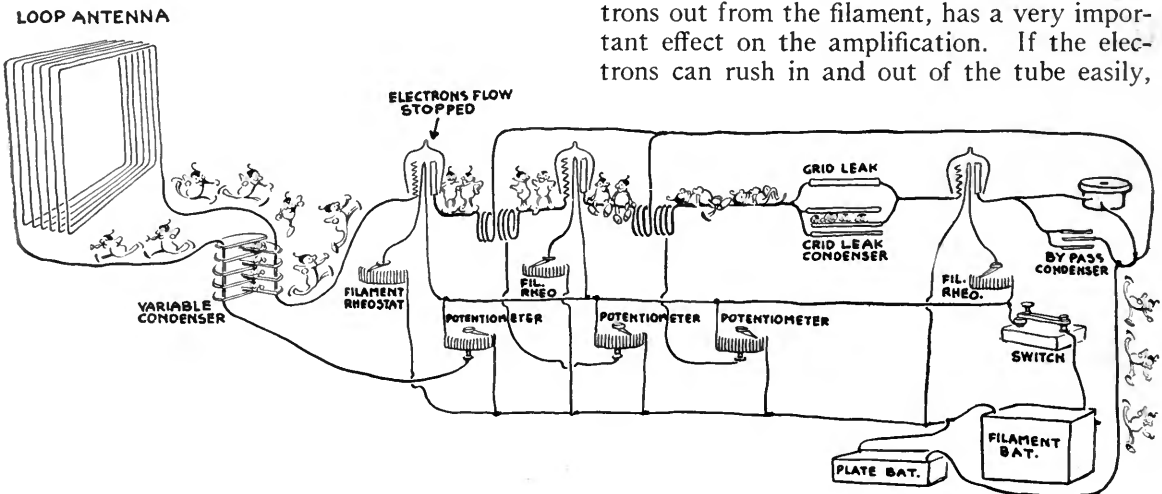

A LOOP ANTENNA MAKES FOR REDUCED INTERFERENCE

It does not collect so much energy as an outdoor antenna, however, and needs an amplifier to help it out.

they will do little real work in the way of giving amplification. As the "impedance" or reaction to their intrusions is increased, the force they will develop as electric pressure or voltage will be increased to a point where it will do useful work. Fortunately, this is readily accomplished by making the grid of the tube more negative than usual. By this is meant the average electric condition of the grid, before any action due to radio signals starts. Under these average conditions, the grid is made to have a concentration of electrons on it. This is determined in turn by the number of electrons on the part of the circuit to which it is connected. The first grid is connected directly to the loop aerial or antenna. The other end of this loop is connected to the filament. If it is connected to the side of the filament which is directly connected to the negative side of the filament battery, the whole arrangement will react back like the House that Jack Built to make the grid negative; the whole loop and the grid as well will have the same negative condition as the negative side of the filament which means a large number of electrons already on them. Under these conditions it may be said that the capacity of the grid is already pretty well used up. And practically no more electrons are going to it from the filament inside the tube. Likewise the plate current inside the tube is greatly decreased. Therefore with very few active electrons passing in the tube, the resistance between the filament and grid is likewise greatly increased. So the "impedance" of the grid to a further rush of electrons produced by radio signals will be high.

The whole action of the radio-frequency amplification starts in the development of rushing electrons in the loop in step with the oncoming signals. If this rush happens at a certain instant to be in such a direction that the side connected to the grid receives a rush of electrons, even though only a relatively few get on the grid, these intruders will produce a comparatively large change in the grid voltage. This will in turn decrease the plate current in the output of that tube to a greater degree as has been described by King Electron in previous accounts. This plate current decreases through the primary coil of a coupling trans-

former to which it leads directly. This transformer consists of two windings, the first or primary connected between the plate battery and the plate of the first tube; and a secondary winding very close to the primary, and connected between the grid of the next tube and back to the negative side of the filament of this second tube. For exactly the same reasons as given before, for the back connection

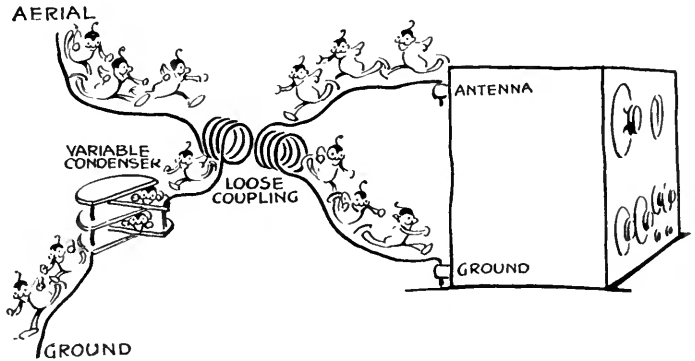

MAKING A DOUBLE-CIRCUIT TUNER FROM YOUR SINGLE-CIRCUIT ONE

The two coils have 25 to 50 turns. The variable is of about .0005 mfd. capacity

of the loop to the negative side of the first filament, this back connection of the transformer to the negative filament makes the grid of the second tube negative.

Now there are electrons in both primary and secondary of the transformer as connected, and as any motion of electrons in one side will be resented by those in the other side to such an extent as to make them rush in the opposite direction, a change to slow down the electrons in the plate current will react to make a change to speed up the secondary electrons of this transformer. This secondary connects directly to the grid of the next tube, so the electron change will act directly on the grid of the second tube. As the grid has a great effect on the plate current, the effect is amplified successively through the radio amplification stages. The reaction goes on through one, two, or three stages. It is then made to act on a grid-leak condenser to give detection as previously described and the consequent desired signals are produced in the connected telephones.

As a matter of fact, it is frequently necessary to make the grids of radio-frequency amplifier tubes more negative than even the negative side of the filament. For this purpose, it is

necessary to add small extra dry batteries between the secondary of the transformers and the negative filament of the tube. These are called "C" batteries. The positive side of these batteries will be connected to the negative side of the filament, and the negative side of these batteries will be connected to the back end of the transformer secondary. This extra negative action will push even more electrons through the transformers into the grids of the connected tubes. These extra batteries need only be very small—the kind used in flashlights. The two-cell or three-volt type will generally be sufficient, but it is well to have some three-cell (4.5 volt) ones for trial. The current which they take is practically nothing, so their life will be that of their ordinary deterioration.

A more adjustable arrangement which will make a radio-frequency outfit cover a wide range of frequencies or wavelengths is provided by the use of "potentiometers." These potentiometers are high resistances placed across the filament battery. A sliding contact on such a resistance is connected to the back connection of the transformer which carries the electrons back to the grid. As this slider is moved over the resistance, it will take up the electric potentials which correspond to electron densities along the resistance, and this is the reason for the name "potentiometer." This density will be greatest at the end of the resistance connected to the negative terminal of the filament battery; and least at the positive end. By varying this, it is therefore possible

to get a smooth variation over the range. It is well to put the tube rheostats in the negative leads from the battery instead of the positive as is done with audio amplification. The potentiometers are directly across the filament battery. This makes it possible for the connected grids to be more negative than the negative side of the filament by the amount of resistance in the filament rheostats, and does away with the need of any extra "C" batteries. If the tubes are turned out by using the rheostats, the potentiometers will still be in circuit, so it is well to have a main switch to disconnect the filament battery from the whole set. This switch also makes it possible to leave the separate rheostats at their best adjustment.

By the use of radio-frequency amplification, much better results may be accomplished in the way of selectivity, as the input power may be reduced to a minimum. Such radio-frequency amplification is of course applicable to double-tuner sets where loose coupling is arranged. There is little if any advantage in using radio-frequency amplification on single-circuit tuners connected directly to an antenna.

As a matter of fact, the radio inspectors have been doing very careful and helpful work over the whole country in arranging slight changes in the wavelength for the broadcasting stations to eliminate as far as possible any beat-note interference between transmitting sets; and with equal care in the design and use of the receiving lay-out good results may now be obtained by the listener-in.



# Listen to These

Some "Inside Dope" on Four More "Stations that Entertain You": WOC in Davenport, Iowa; WHN in Ridgewood, Long Island; PWX in Havana, Cuba; and KHJ in Los Angeles, California. You Must Be Within Range of At Least One of Them

I HEARD Davenport, Iowa, last night," says Smith to Jones.

"That's nothing," replies Jones to Smith, "I get Havana 'most every night. On one tube, too."

"You don't say!"

Smith is crushed, impressed, and interested.

"Sure—but of course you've got to know how to tune your set. You can't just sit in front of it and twirl the dials around, in the hope that some far-away stations will speak up. Now, for instance, when I start in to tune—"

And they're off in a cloud of dust. Facts that

sound fishy, and fish stories that sound more or less like facts are reeled off with equal glibness and solemnity.

Judging from the lists that have been sent to RADIO BROADCAST in the "How Far Have You Heard on One Tube?" contest, however, the midnight radio anglers are making the most of their opportunities during this "open season."

The four stations shown this month have widely different geographical locations, representing the Atlantic Coast, the Pacific Coast, the east central part of the United States, and the territory beyond our southern boundaries.



"WHERE THE WEST BEGINS AND THE TALL CORN GROWS"

The stuffed birds hovering near the ceiling, the bits of wisdom stenciled on the walls, and the "rustic" furnishings give this-music studio of the Palmer School of Chiropractic in Davenport, Iowa, an unusual appearance, to say the least



THE ATTRACTIVE STUDIO AT WHN, A LOW-POWERED STATION AT RIDGEWOOD, L. I.

THE IMMACULATE OPERATING ROOM AT PWX, HAVANA, CUBA

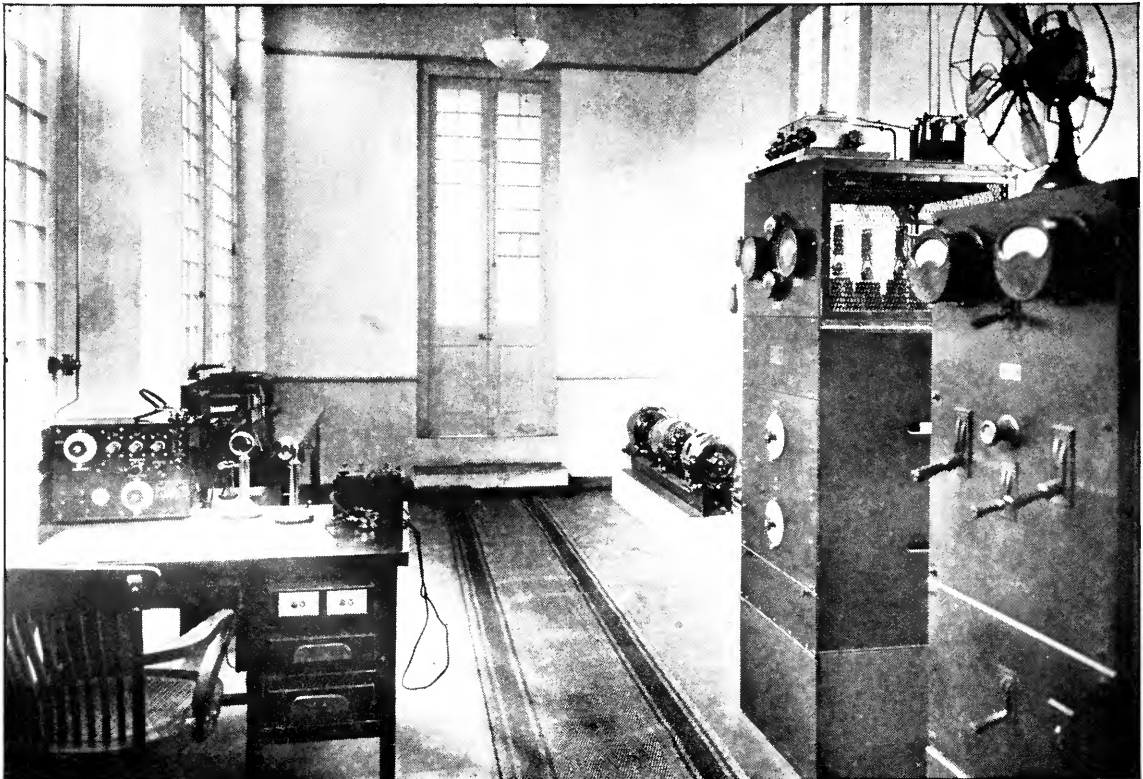

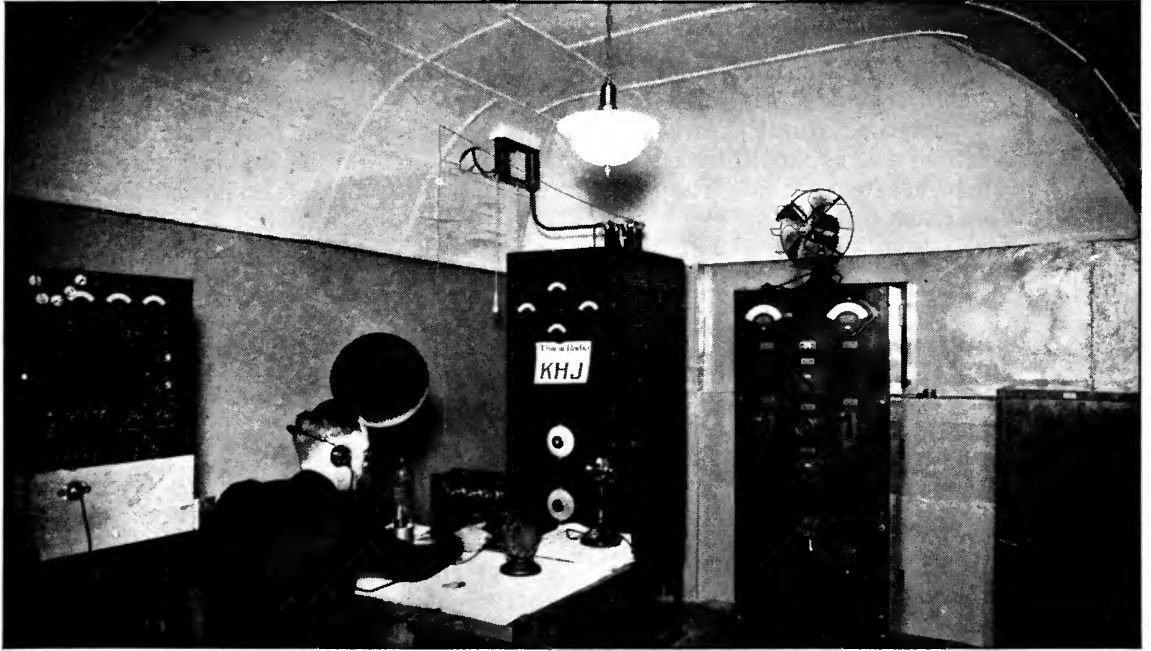

OPERATING ROOM AT THE LOS ANGELES "TIMES" STATION

## Litzendraht vs. Solid Wire

By RALPH R. BATCHER

Engineering Staff, Western Electric Company

**L**ITZENDRAHT, a special cable composed of a number of strands of fine insulated wire, has long held the reputation of giving lower losses with radio-frequency currents than any other type of wire. The statement is not without foundation, for in most cases coils of high grade Litzendraht may show a five to fifty per cent. decrease in resistance, compared to solid wire, *if all the strands are perfect.*

On test, it has been found that a coil employing litzendraht may act perfectly for six months or a year, and then develop troubles which indicate a broken strand or so in the cable with which the coils are wound. This often occurs, no matter how carefully the coils are manufactured, mounted and tested, although it does not make the set inoperative and would pass unnoticed by many users. Manufacturers who are intent on satisfying the most discriminating amateur have investigated all factors which cause excessive resistance in litzendraht coils.

Recent experiments have shown that solid copper (No. 25 B. & S.) with one layer of cotton and one of silk, is equivalent to the litzendraht used (20 strands of No. 38). Complete measurements were made on equivalent coils so that a direct comparison might be made. To make sure that there were no broken strands to begin with in the litzendraht, each strand was tested for continuity separately, stripped of enamel and separately tinned. Upon soldering, the complete direct-current resistance of the cable was measured and checked with the theoretical resistance. When tests were completed on this coil, one strand was intentionally broken at one end and the tests repeated, after which another wire was broken at the opposite end.

The first was a practical test in a receiver. It was found that the solid wire coils will oscillate (for c w reception) with the filament current just as low as when the perfect stranded wire coil was used. This test was thought to represent actual receiving conditions.

The high-frequency resistance was next measured. With ordinary methods of measuring high-frequency resistance, it is impossible to separate the resistance from the impedance, and as the measurements were made at frequencies very near the natural period of the coil, the resistance was apparently greatly increased at the higher frequencies. The reason for this will be taken up later.

A graphical presentation of the results is shown on the accompanying graph. Curve "A" represents the apparent resistance of the coil wound with litzendraht in which each strand was tested and found perfect, and perfect connection made with each strand at each end. Curve "B" shows the apparent resistance for the similar coil wound with solid wire. Curve "C" shows the same coil as used in "A" with one strand purposely broken near one end.

It will be seen that Coil "A" has the lowest resistance. Strictly speaking, however, Curve "B" should be moved 25 meters to the left in order that direct comparisons may be made, as it happened that in this case the solid wire coil had a natural wavelength 25 meters higher

than the litzendraht coil. This difference is relatively small and may be due to any of a number of reasons.

Curve "C" has several outstanding features: the distributed capacity has increased apparently to about four times its original value, since the natural period is about doubled. There is also another frequency lower than the fundamental, at which the resistance increases.

Another strand was broken, this time at the end opposite the first break. The result was that the coil seemed to respond slightly to several wavelengths other than its natural one, giving a curious effect in tuning and being very poorly adapted for precise work in a regenerative receiver.

The apparently high resistance shown on the curves at the lower wavelengths may surprise some radio experimenters. That these results are logical may be shown by the fact that theoretically a coil has infinite impedance at a frequency corresponding to its natural wavelengths. In fact, any inductance shunted by a condenser (in this case it is shunted by the distributed capacity) will act as a very high impedance to frequencies at and near the natural or resonant frequency of the combination.

We can, however, console ourselves by the fact that a large part of this apparent resistance at such frequencies is due to the reactance, and so will not absorb energy and produce heat as a real resistance would. The method used for measuring the above resistance was to couple the coil very loosely to a vacuum-tube oscillator. A thermo-couple, condenser (variable, having negligible losses) and a high-frequency resistance box made up the rest of the circuit with the coil. The change in the deflection of the galvanometer across the thermo-couple was noted when resistance was added to the circuit and the coil resistance computed from such data.

The problem then resolves itself into choosing the lesser of two evils. Laboratory measurements show litzendraht superior as long as it is in good condition. Actual tests in a receiver show apparently no difference as far as sharpness of tuning is concerned or for its qualities in an oscillating circuit. It is believed that the desire to safeguard the user from the freakish effects of broken strands is enough to throw the balance over in favor of solid wire.

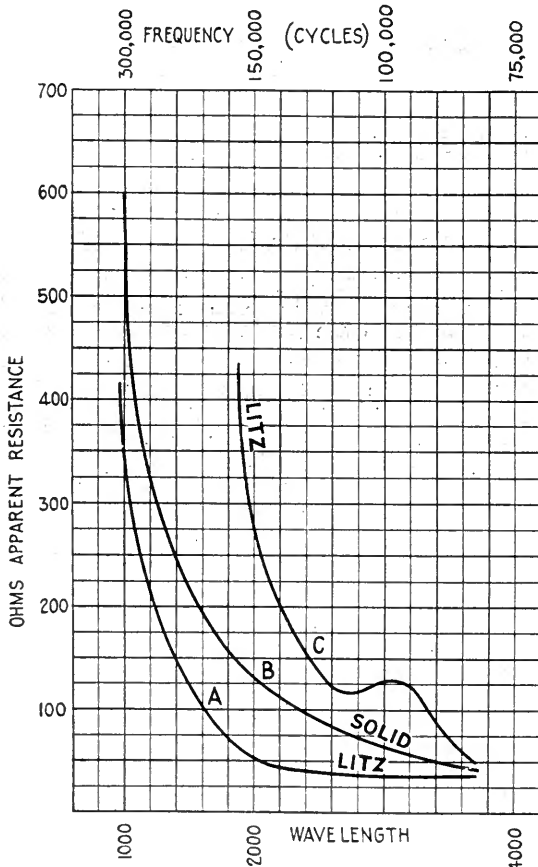



# Simple Bulb Transmitters

By ZEH BOUCK

## PART IV

### Alternating Current Systems

**A**C. TUBE transmitters are classified, according to the characteristics of the plate supply, as rectified or self-rectified sets. In rectification systems, the 110-volt alternating current is transformed to an adequate plate potential, and passed through rectifying apparatus where it is changed to direct current. It is then filtered in the manner described last month for the output of a motor-generator, and finally applied to the plates of vacuum tubes, the oscillating output of which may be modulated at voice frequencies for the transmission of speech. Radio telephony is thus simplified to the extent that all power may be obtained from a single electric light socket. At the same time the noise and moving parts of the motor-generator are eliminated. A. C. radio telephones generally represent a less formidable initial expenditure, and when properly and intelligently operated, give results comparable to those secured with a motor-generator.

Self or unrectified sets employ the "raw," stepped-up A. C. as the plate potential, without modifying it by filters or similar apparatus. This system has become especially popular with amateur stations working distance, where it solves the problem of an economical, high-power C. W. transmitter.

As any one terminal of an alternating current supply is positive for half an alternation, it is capable, during that time, of supplying a vacuum-tube plate with the current essential to oscillations. Such circuits are "self-rectifying" in the sense that the tubes automatically use the positive fluctuation of the current, and cease to take current or oscillate when the terminal feeding the plate is negatively charged. Bearing in mind that a flow of electrons constitutes a plate current (which is necessary for oscillations), and that electrons, being negative, are repelled by a like charge, Fig. 1 will clarify the phenomenon of self and

plain rectification. The three progressions indicate, respectively, the alternating current fluctuations in the power transformer, the resulting variation of the plate charge, and the accompanying effect on the oscillating output.

If two oscillating tubes are used in a self-rectifying circuit, the plates being supplied from the opposite terminals of the transformer (one of which is always positive), each tube will operate on the opposing half of the cycle, giving a more smooth and powerful wave. The radiated output of the second tube, which is really the complement of the first, is indicated by the dotted oscillations in Fig. 1. The frequency of the combined oscillations is, of course, double that of the single bulb, and a far more pleasing tone. Utilizing both halves of the cycle in this manner is often referred to as full wave self-rectification.

Attempts have been made to adapt full wave self-rectification to the transmission of speech and music, but to the knowledge of the author, experiments in this direction have been only partially successful. For radio telephony,

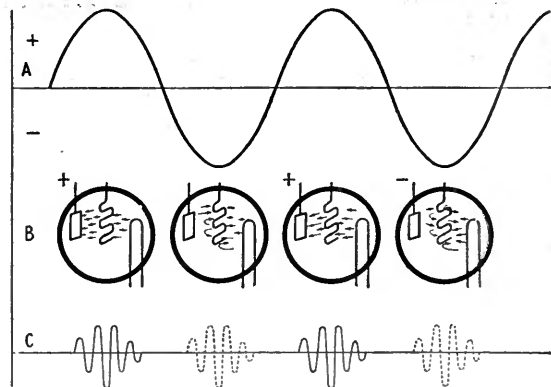

FIG. 1

operated from an A. C. source, separate rectification must be employed.

This is commonly accomplished by either of two methods, bulb or chemical rectification.

The latter is the more economical system, but often requires considerable experimentation before success is achieved. As explained above, an audion will pass a current in only one direction, from plate to filament, the phenomenon on which bulb rectification is dependent. The grid does not function in this operation, and rectifying tubes are generally built with only two elements, the plate and filament.

A typical bulb rectification circuit is indicated as that part of Fig. 3 enclosed in dotted lines. P is the primary of a transformer designed to operate on 110 volts, 60-cycle current. R. F. is a secondary winding giving eight volts across the outside terminals, and supplying current to the rectifying tube filaments. P. F. is likewise an eight-volt filament winding, and lights the 5-watt power tubes. Though this last winding is indicated as a part of the power transformer, it is often desirable to wind it as a single secondary on a separate transformer, such as described in the January RADIO BROADCAST. S is the high-voltage secondary, giving 1100 volts between terminals X and X'. All secondaries are tapped in the middle.

The centre tap Y is always negative in re-

spect to the positive terminal of the high-voltage secondary, a charge that alternates between X and X'; and is therefore the negative high-voltage lead. When X is positive, a current passes through rectifying tube number one, the filament of which (or terminal Z) is charged positively in respect to Y. In the next fraction of a second, conditions are reversed, and X' is now the positive terminal of secondary S. Tube one, with the plate negative, ceases to function (Cf. Fig. 1) while bulb two passes a current; positive electricity again being drawn from Z. Thus Z, which is plus regardless of current alternations, supplies the positive potential to the plates of the power tubes. As only half the transformer secondary (550 volts, between the terminals and the centre tap) is applied to the radiophone circuit, and allowing for a voltage drop through rectification, the plate potential will approximate 400 volts, the general working voltage for 5-watt tubes. The plate voltage may be further decreased, in order to reduce power, by lowering the rectifier filaments. However, the voltage should not be dropped more than 50 to 75 volts in this manner, as the A. C. hum is likely to be emphasized when the rectifying



FIG. 2

Material for a 5-watt rectified, radio telephone transmitter, using two rectifying tubes and two power bulbs

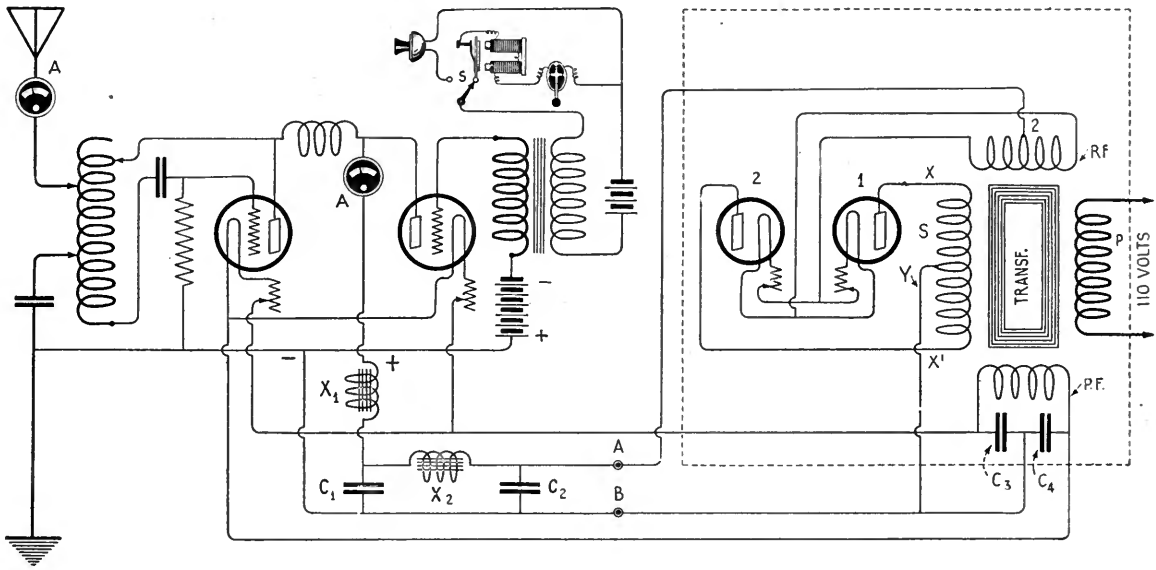

FIG. 3

The circuit used with the equipment shown in Fig. 2. This system is fundamentally the Colpitts oscillator with Heising modulation

tubes are burned below their normal brilliancy.

The special transformer for rectification is best purchased, but the intrepid experimenter may build his own, following the general procedure outlined in the preceding issue of RADIO BROADCAST for the construction of a filament lighting transformer. The core should be built up two inches high in the same manner, using 10" x 2" soft iron strips. The exact dimension of the core may be varied as occasion necessitates, but the cross-section must in all cases approximate four square inches. The secondaries are best wound on three legs of the transformer. Care must be taken to insulate the four windings for 1100 volts, and empire cloth or tape should be used generously.

The primary is wound with 300 turns of No. 15 single cotton covered wire. The two filament lighting secondaries are each wound to 24 turns with No. 9 single cotton covered wire; and the high-voltage secondary with 3000 turns of No. 27 double cotton covered wire. The secondaries are wound in two sections or pies (both windings in the same direction); the finish of the first pie connecting to the first turn on the second, and the joint brought out for the centre tap. Every other layer of the high-voltage secondary should be insulated with a single covering of empire cloth or tape.

The various units used in the construction of a bulb rectifying set are shown in Fig. 2. The

circuit is indicated in Fig. 3, and is fundamentally the Colpitts oscillator with Heising modulation, the operation and values of which were described in detail in the January number. Tuning and the adjustments of the modulating circuit are effected in the same manner as was suggested for the D. C. apparatus. The substitution of rectified A. C. for the motor-generator, necessitates no change in the constructional details, excepting the chokes  $X_1$  and  $X_2$ , and the condensers  $C_1$  and  $C_2$ . These chokes and condensers constitute the filter system, and as the ripple accompanying rectification is more difficult to eliminate than the comparatively gentle hum of a D. C. generator, they must be of larger sizes. The reactance coils (chokes) are each wound with three pounds of No. 27 single cotton covered wire, on 10-inch cores with cross sections of approximately three square inches.  $C_1$  and  $C_2$  should have a combined capacity of at least ten microfarads.  $C_3$  and  $C_4$  are capacities similar to those shunting the filament lighting transformer in the motor-generator installation, and may be paper-foil condensers such as are used across spark-coil vibrators.

#### ELECTROLYTIC RECTIFIERS

RECTIFICATION is accomplished in a chemical rectifier by the electrolytic action of different solutions on aluminum which, when that metal is used as an electrode,

will permit electricity to pass through it in only one direction.

The chemical rectifier is much cheaper than the bulb system, and its installation, exclusive of the transformer, should not exceed three dollars. The rectifier is constructed in the form of small jars, the number and size depending on the current which they are to pass. The jars are best built in a rack after the fashion of a storage "B" battery, and a twenty-jar set of the jelly glass variety will adequately handle the plate current for a 5-watt set. The electrodes are of lead and aluminum strips, one inch wide, three inches long, and one sixteenth of an inch thick. Each jar contains one lead and one aluminum plate, separated by thin blocks of hard rubber, the whole being bound into a compact unit with rubber bands (Fig. 4). One corner of the aluminum plate is drilled, and a brass nut and bolt passed through the hole and tightened over a short length of copper wire lead. The twenty jars are broken up into groups of ten in series, the wire on each aluminum electrode being soldered to an adjacent lead plate. The active elements (aluminum) at the end of the two series are joined, a connection that forms the positive lead, while the lead plates are connected individually to the terminals of the high-voltage secondary, the centre tap of which is again

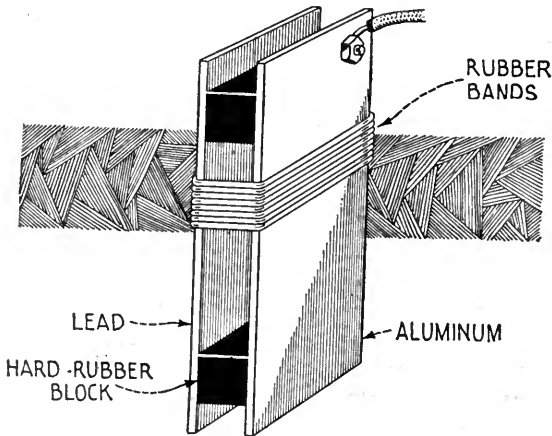

FIG. 4

negative (Fig. 5). The transformer may be identical with that used in bulb rectification except that the rectifier filament winding is eliminated.

Care must be taken in securing the aluminum, as the success of the rectifier is directly dependent on the purity of the metal. Aluminum sheet, especially "formed" for this

purpose, may be obtained from Eimer and Amand, 240 West 42nd Street, New York City.

Several electrolytes are in common use, but the most satisfactory solution is probably made by mixing six ounces of *pure* phosphoric acid to one quart of *distilled* water. The best grade of ammonia is then added until the mixture tests neutral with litmus paper. After the mixture has cooled, ammonia is again added in small quantities, until there is just sufficient to turn the litmus paper blue, i. e., the solution is slightly alkaline.

If it is impossible to obtain phosphoric acid, it may be replaced by boric acid, of which a saturated solution is formed with distilled water. In accomplishing this, it is best to heat the water, and stir in the boric acid until no more will be dissolved. On cooling, a portion of the acid will crystallize, indicating that the solution is truly saturated. Ammonia is added as before, until the electrolyte tests alkaline.

The solution for all jars must be made at one time, in a single receptacle, and poured into the cells until an inch and a half of the plates is covered. The rectifier is then ready for use, and is made part of the Colpitts circuit by connecting the wires A and B (Fig. 5) to the correspondingly lettered leads in Fig. 3.

Many experimenters employ an electrolyte consisting of a saturated solution of borax. This is made by dissolving as far as possible a portion of a ten-cent package of 20-Mule-Team Borax in one quart of distilled water. While this is cheaper than the phosphoric acid solution, and obviates the litmus testing, it is necessary to "form" the plates before the rectifier will operate. This is accomplished by subjecting the rectifier to the high potential, first for a minute at a time, then gradually increasing the period until the transformer secondary ceases to heat under the load. During the preliminaries, until the plates are formed, the jars are virtually a short-circuit.

When the rectifier is working properly, there is generally a gentle glow about the aluminum plates, and the temperature rise in the solution, or transformer secondary, if any, should be barely perceptible. There should be no pyrotechnics, and the presence of such is indicative of overloading, which may be remedied by adding more solution or increasing the number of jars.

Electrolytic rectification is an interesting and instructive experiment, and so cheap a one,

that the experience of building even an unsuccessful rectifier is well worth the cost. If the experimenter is at present transmitting on a small B battery radiophone, such as has been previously described, he is advised to adapt it to electrolytic rectification, following out the

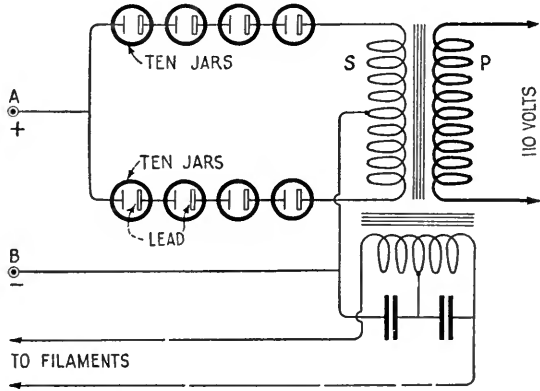

FIG. 5

principles demonstrated in applying this system to the originally direct-current Colpitts circuit. Indeed, it would be well to construct especially, a 5-watt set of simplified design, in order to become familiar with the characteristics of rectified operation, before attempting to build more complex apparatus.

AN EXPERIMENTAL 5-WATT SET

SUCH an installation is indicated diagrammatically in Fig. 6, and the cost of the various parts should not total more than twenty-five dollars! The apparatus has been

boiled down to essentials, and the set is operated altogether from power supplied by a single A. C. lamp socket.

Excepting for the rheostat, microphone, bulb, socket, the 5000-ohm grid-leak, C<sub>3</sub>, C<sub>4</sub> and C<sub>5</sub>, the set is home-made. If the amateur has facilities for the construction of any of these items, the cost of the set will be still further reduced. Inductance L<sub>1</sub> is wound with 40 turns of any convenient insulated wire under No. 22 and tapped every fourth turn. L<sub>2</sub> is a single turn of wire wound over L<sub>1</sub>. C<sub>1</sub> is a fixed capacity of three to eight plates (to be determined by experiment) of one by 3-inch tin-foil (two square inches active area) separated by mica. C<sub>2</sub> is similar to C<sub>1</sub>, using however, only two or three plates. X has already been described, and C<sub>3</sub> may vary from two to ten microfarads, the higher capacities being desirable. C<sub>4</sub> and C<sub>5</sub> will probably cost the experimenter nothing, but in advent of his inability to obtain the spark-coil vibrator condensers, telephone shunt capacities of .0025 mfd., used for receiving purposes, may be substituted. The only variation in the rectification transformer from that designed for the Heising modulation set exists in the secondary S, which is wound to 2500 turns, a reduction that permits the cutting down of the rectifier to sixteen jars. A radiation ammeter should be borrowed for tuning the set.

Tuning and operating is done as suggested for the D. C. installation in the January RADIO BROADCAST.

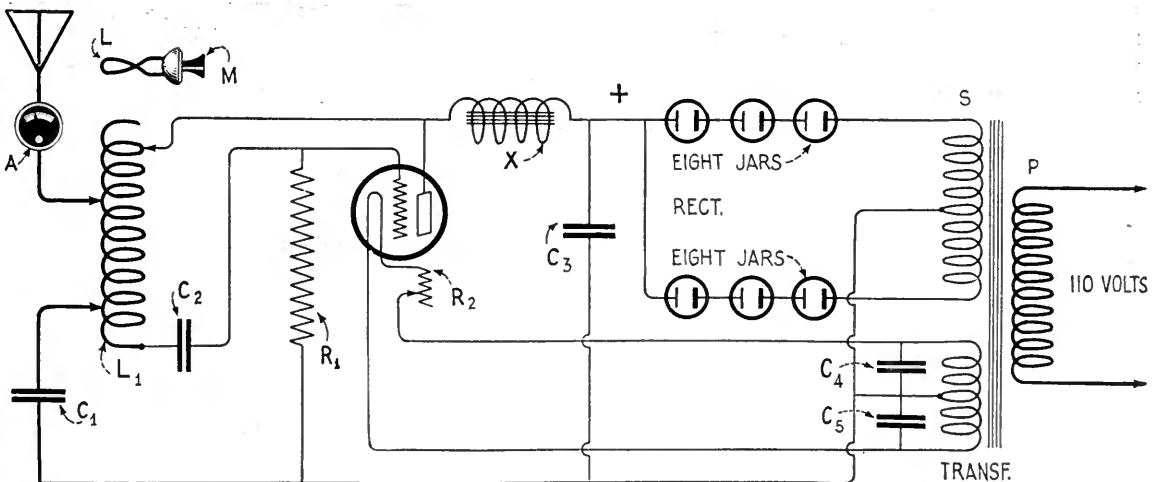

FIG. 6

Diagram of a 5-watt set, operated by power from a single A. C. lamp socket

# Cave-Man Stuff, But It Works

A Rough but Ready Outfit that Gives Excellent Results on One Tube.  
Some Pointers on the Delicate Art of Bringing in Long-Distance Stations

By I. R. TANNEHILL

IN THE average discussion of the single-circuit, single-tube, regenerative receiver, the writer starts off with the single circuit but is unable to confine his remarks to the subject and introduces a vast hash of selectivity, inductively coupled circuits, variometers, electrons, loop aerials, and radio-frequency amplification. It may be that the single circuit is less selective, but the average beginner finds any type of radio receiver so selective that he has trouble hearing anything at all. Hence why trouble him with methods of tuning out interference?

Confidentially, I believe that every one of these writers is guilty of the variometer habit and that his cellar or attic conceals a number of parts that do not fit into a single circuit. Have any of them conscientiously and consistently employed the single tube and the single circuit? If so, why do they claim that it requires two stages of radio and two of audio amplification to pick up a station 200 miles distant?

I have for one year employed the single vacuum tube in a single circuit more than any other type of receiving apparatus. Located in southeastern Texas, the home of static, I have frequently heard stations 1,000 miles away and for long-distance reception I would have nothing in preference to a single-tube, single-circuit receiver. My aerial is fifty feet long, one end tied to the chimney and the other to a two-by-four nailed to an outhouse. My

phones cost \$4.37 and my vernier condenser, the pride of my outfit, was made from the plates of a knock-down condenser that I was never able to assemble as directed. The knob on the condenser is one of my wife's clothes pins.

From the above remarks you can readily see that I am a first-class "ham". I have never soldered a connection. The only time I tried it I succeeded in making nothing but a lot of smoke. Every time the wind blows I am afraid my aerial will fall down. Yet fourteen of the stations I have heard with this outfit give an aggregate mileage of 11,950.

In every instance I found by making inquiries that others in town had heard the same stations on similar sets. Therefore the freak, as it has been termed, was not due to the set but perhaps to atmospheric conditions. As far as the freak is concerned, I feel sure that it was about 50 per

"The listener who does not occasionally hear stations farther away than 500 miles," says the author of this article, "is either in a dead zone or is not acquainted with his apparatus. If he tunes his set systematically instead of turning the knobs in a haphazard manner with the hope of accidentally hitting an adjustment, he will get results. The directions herewith may not conform with the practices of the manufacturers of apparatus, but manufacturers do not guarantee any great ranges and furthermore do not furnish directions with the apparatus that would enable anyone to get great ranges. You get thirteen pages of directions with a liver pill and practically nothing with a radio receiver!"

Some of Mr. Tannehill's home-made equipment may lack finish and compactness, and we should hesitate to endorse his practice of never soldering a connection; but he does get results. The method of tuning described in this article should help many set-owners to improve their receiving records.—THE EDITOR.

cent. atmosphere and 50 per cent. careful and patient tuning.

A1 (cost \$2); C1, .001 mfd. (\$4); C2, 3-plate (\$3); GL, grid leak, combined with C3; C3, .00025 mfd.; S, tuning coil (25c. to make); R, tickler coil (25c.); G, ground to water pipe; C4, approx. .001 mfd. (35c.); T, (\$5); B, 22.5 volts (\$1.50 to \$3); R, rheostat (about 75c.); VT, tube (\$5 to \$8).

The tuner may be a variocoupler. Parts can be purchased for about \$1.50 to \$2.00. A cheaper and really more satisfactory procedure is to cut two narrow rings from a

cardboard tube. Wind fifty turns of No. 26 or No. 28 wire around one, tie the ends around the rings, and leave about a foot or more of wire at each end for connections. Around the other wind about sixty turns and secure in the same way leaving leads for connections. Screw two curtain pole brackets into the end of the table, lay a piece of broom pole across them and hang the two coils on the pole (see photo, p. 329). Set four binding posts into the edge of the table and fasten these four coil leads between the bolt head and washer of the binding post, leaving the binding post for other connections unless you wish to tie more than one wire into the clamp of the post. This tuner is very satisfactory and will cost about 50 cents to 75 cents. Use the 50-turn coil for a tickler and the 60-turn coil for a tuner. After testing the set you may find that there is too much wire on the tuner, in which case remove a few turns at a time while testing.

Connect the other apparatus as shown in the diagram. Increase the brilliancy of your filament until a slight hiss is heard. Decrease it till you are just below the hissing point. Do this with your two coils at extreme ends of the pole or with rotor of variocoupler vertical. Bring the coils together. Rotate your condenser plates and you may hear the tube oscillating. The oscillation of the tube usually takes place more easily at the low capacity end of the condenser, or in other words with the condenser nearly open.

This is the primary consideration for the beginner if he must tune in long distance stations. The tube must oscillate with the coils close together. When the tube is oscillating there is a mushy sound in the receivers, something like a faint rushing of air. The static noises become louder as the point of oscillation is approached either by turning the condenser or moving one of the coils back and forth. Spark signals, if heard, will usually be clear and more or less musical with the tube quiescent, but become hissing noises when the tube is oscillating.

If the tube does not oscillate under this test, then turn one of the coils around and try it again. Instead of turning a coil around you may exchange the two connections to one of the coils. If you are using a variocoupler, make the test with the rotary coil horizontal and if you do not hear the tube oscillating, turn the rotor completely over and try again.

Occasionally you get a tube that does not

oscillate with the usual hook-up. In that case increase the grid condenser to .001 by substituting a fixed condenser of that capacity. You may use the one shunted across the telephones for the grid and replace the phone condenser with one of about .0005 mfd. capacity, also fixed. Oscillation will usually be obtained with a relatively low filament current with these latter capacities.

However, do not fail to try it with the rotor

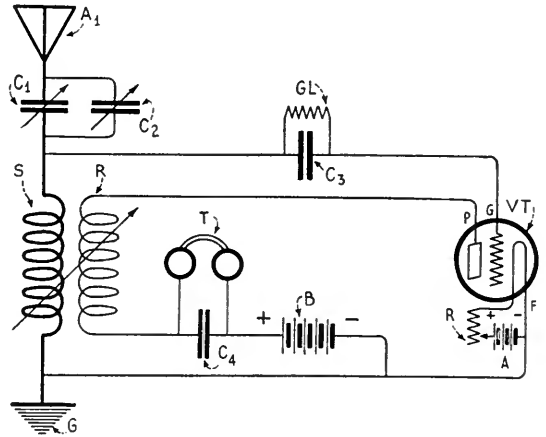

MR. TANNEHILL'S SINGLE-CIRCUIT HOOK-UP

With which he has heard stations  
over 1,000 miles away, with one tube

inverted (or with the coils reversed). Once you have learned how to produce the oscillations it is but a short time until you have learned to control them by changing the filament brilliancy or turning the rotor, or if coils are used, by moving one of them back and forth on the pole.

Occasionally there is almost a total absence of static, spark signals, or other sound, so that it is nearly impossible to determine whether or not the tube is oscillating. This is rare, however, at the present time when there are so many broadcasting stations and amateurs.

The second step is to tune in a telephone station. With the tube oscillating, turn the condenser around *very slowly* and listen for a whistling note. This is the carrier wave of the broadcasting station. As you change the condenser capacity you come upon a high-pitched whistle. As you turn further the pitch of the whistle becomes lower and lower. As you turn on, the whistle repeats itself becoming higher and higher in pitch until it disappears. At the centre of this double wave you will perhaps hear music or voice. If you do not hear the carrier wave, separate your coils

slightly or reduce the filament or incline the rotor slightly and try again. If this test does not produce a carrier wave, then remove a few turns from the tuner coil or try another tap on the stationary coil of your variocoupler (if the latter is used), and try again. With the ordinary antenna and a .001 condenser in series as shown in the diagram, the broadcasting stations should be heard with about 40 to 60 turns of wire on the tuner. In some cases you may require only 35 turns.

*Turn the condenser slowly*, as the broadcasting stations require very sharp tuning when at any distance. After you have obtained an approximate setting with the .001 condenser you will find that the vernier in shunt with it on the vernier attachment will give a much closer setting.

While you are experimenting with this set, your tube will be occasionally in a state of oscillation. Much has been said about the interference that one creates in tuning a regenerative set. Don't let that worry you. *The output of a detector tube will not split anybody's ears.* The fellow who is using four or five hard tubes in an amplifying circuit is the fellow who hears your little wave and usually he is the fellow who is creating all the interference with the tuning of his set. Let the blame rest where it belongs—on the fellow who is using five-watt power tubes in his receiving circuit.

If you try to tune in a distant station without oscillating you will never get anywhere. You can pick up that carrier wave a dozen times easier than you can his music or voice.

Now we shall suppose that you have succeeded in picking up a carrier wave after altering your coils until tuned within the proper range for broadcasts. At the centre of the wave you will hear something that bears a distant resemblance to music or a man's voice that sounds more like the barking of a dog than anything else. Your next problem is to clear it up and amplify it.

You will now have learned that your hand has a capacity effect. While you have your hand on the condenser dial or knob you hear the carrier wave, but when you take your hand away it is gone. Your hand affects the tuning by increasing the capacity. You will therefore find that by increasing the capacity of the condenser till you cannot hear the wave, it comes in when you take your hand away. By experience you will learn just about how much

capacity effect your hand has and make an allowance for it.

Then you learn another thing. You have the carrier wave tuned in at last and now you seek to clear up the music by inclining the rotor of your coupler, or by separating the two coils (if tuning with them), and you find that this also affects your tuning.

When the coils are close together or when the rotor of the coupler is horizontal or nearly so, a slight change in the coupling causes a decided change in the wavelength of your receiver. As your tuning coil and tickler coil are placed farther apart (or as the rotor is inclined toward the vertical) the detuning effect of the movement becomes less pronounced. It is therefore easier to tune and adjust the tickler control simultaneously when the coupling is rather loose, provided that the set is so constructed that oscillation can be obtained with a fairly loose coupling without crowding the filament.

As stated before, the oscillations occur more readily at low capacity in the aerial than at high, as a usual thing. Therefore, on rotating the condenser to decrease the wavelength, the set breaks over into self-oscillation. It may do this very gradually, beginning with a slight hiss, or it may do so with a sudden popping sound in the receivers. The latter state is difficult to control and causes a great deal of trouble in tuning. It is usually due to operation at too high a filament temperature. Reduce the filament temperature until the oscillations are set up gradually with change of capacity.

Having established these conditions, you are ready to tune in the broadcasting station. A distant station may be tuned in systematically by the following method. Increase your condenser capacity until the removal of your hand leaves the upper or high wave portion of the carrier whistle in the receiver. Then incline your rotor until you pass through the centre of the wave and beyond to the low-wave half of the whistle. Again increase your capacity until you are set on the upper half of the wave. Incline the rotor (or separate the coils as the case may be) until you are again on the lower half of the wave. As you alternate from one side of the wave to the other in this fashion the wave becomes more and more pronounced and the music or speech at the centre becomes louder and clearer. You are approaching the point of regeneration.



When this procedure has brought you to such a point that the next increase in condenser capacity shows you that the upper portion of the carrier wave has disappeared, you are very close to a perfect adjustment. The last few settings of the condenser are best made with a vernier condenser of about three plates. A condenser with capacity of .001 with a vernier plate can be used instead.

If the station is about 50 to 100 miles away, tuning should be easy. At 500 miles a little care is required to tune in the stronger stations and considerable patience in tuning in the faint stations.

At 1,000 miles with a single tube you must make accurate allowance for the capacity effect of your body; you must avoid any jar of your equipment; you must

not change your position in front of the receiver; and you must have patience.

In other words, at distances in excess of 1,000 miles you must "sit in the middle of the boat, keep your hair parted in the middle, keep your stogie on the same side of your face, etc. (though I never could say that there was any decided effect from the hands of my watch moving around!)" In this way I have listened with great enjoyment to a concert at a distance of 1,100 miles for more than an hour without any but slight cramps. I remember about a year ago watching a man tune in a Detroit station at a distance of more than 1,000 miles while a friend (not myself!) sat carelessly with his feet on the work bench beside the receiver. Just as he succeeded in tuning in with complete satisfaction and told us to listen, his friend took his feet off the table. We could hear nothing.

Of course, with stations at that distance, the receiver does not remain in perfect adjustment. Because of slight changes in capacity of the aerial, due to swinging or other causes and perhaps to changes in filament current, a slight

adjustment of the rheostat or vernier condenser is occasionally required. It is my experience that anywhere from 10 to 30 minutes is required to make a satisfactory adjustment of the controls to tune to a station at a distance of 1,000 miles.

I confidently believe that any listener with a single-tube set, unless in unfavorable territory, can hear stations at that distance, though of course manufacturers will not guarantee any such

ranges. This is largely because old man Static has a habit of running a file across your lead-in wire, pouring shot down your aerial, dumping gravel into your condenser and emptying wagon loads of hard coal into your battery.

But don't be afraid. Buy your parts, tie them together, part

your hair in the middle and go after Havana and San Francisco and Schenectady. You can hear as far but not as loud with a single tube as you can with two stages of audio-frequency amplification. I have consistently obtained greater ranges with one tube than with three.

The main idea is to get something that will bring in the signals. Afterwards you can worry about selectivity, radio-frequency amplification and shielding.

P. S. The same day the above was written I went home, spent about an hour weeding out the various stations, using one tube, and finally picked up WGY at Schenectady perfectly at a distance of about 1,450 miles. On turning on two stages of audio-frequency amplification this station was as strong as one could listen to comfortably with a headset on. Tuning-coils used were as described above—two homemade coils on a piece of broom pole. And please note that the above results are only ordinary. There are many men here who claim to have heard Kansas City stations on a crystal.



THE PRIMITIVE BUT EFFECTIVE VARIOCOUPLER

Shown at the left, consists of two coils wound on cardboard rings, and slides on a section of broomstick. Sixteen-months-old Doris Marie Tannehill is listening intently to whatever this extraordinary set of her father's is bringing in

# A Super-Sensitive Long-Range Receiver

Another Invention of Edwin H. Armstrong Which He Calls the "Rolls-Royce" Receiver

By PAUL F. GODLEY

**A**RMSTRONG, of radio receiver fame, called it a "Rolls-Royce." He named one after the "flivver," too. It was his single-tube super-regenerative receiver. But, notwithstanding the marvels which are to be unearthed from beneath the intricacies of the super-regenerative scheme, the real "bug" on radio reception methods — super-sensitive radio reception methods—has a very keen and long unsatisfied hankering to know all about that *most sensitive* receiver, the super-heterodyne.

That long-to-be-remembered sporting proposition so spectacular and successful in its outcome, the bridging of the Atlantic last winter by American amateurs, brought the super-heterodyne receiver into the limelight. Armstrong's phrase, "the Rolls-Royce receiver"—a phrase which he coined at the time of his disclosure of the super-regenerative receiver, added considerable prestige to that intriguing and mystifying word, "super-heterodyne."

And, when, in starting to learn about the super-heterodyne, the reader finds the statement that it is a method of radio-frequency amplification, he is not for one moment to jump to the conclusion that radio-frequency amplification by the super-heterodyne method is by any means an ordinary method. It is perhaps the simplest of receivers in operation. At the same time it is, no doubt, the most complicated of receivers to construct because of the care which needs to be taken with it.

Let it be said for the benefit of those few who

may not yet have learned it, that the three-element vacuum tube as a detector of radio oscillations has an adjunct which is known as its "threshold value." To be specific, the three-element vacuum tube will not function as a detector until the incoming oscillatory currents are of a certain disappointingly large value. As a result of this defect (we are

sorely tempted to call it that), many, many surging signal currents come to dwell in our antenna and receiver circuits, unannounced and unknown. Long ago their presence there had been suspected and, even in early times, methods which we would now consider quite crude were employed in an attempt to make their acquaintance. Primarily, most of these attempts had to do with amplifying the

audible signal currents in the belief that after the weaker signals had operated the vacuum-tube detector, they were so nearly exhausted as to be below audibility. Further study disclosed the fallacy of this, and then it was that the great value of employing the three-element vacuum tube in their amplification prior to their detection was discovered.

Radio-frequency amplification has been used for several years, quite successfully, at long wavelengths where the frequency of oscillations is comparatively low. It was not until the World War that any great attention was given to finding out the reasons for the difficulties encountered when radio-frequency amplification was attempted on very short waves. Here the oscillatory currents are of comparatively high frequency. Up to this

## The Super-Heterodyne

Here, again, we find the practical genius of Edwin H. Armstrong, inventor of regeneration and super-regeneration, applied to a receiver designed to help America terminate the World War. Again we find a war development of great peace-time value. For many years Armstrong and the author of this article have been close friends. It is not surprising, therefore, that Godley knew of the super-heterodyne receiver and used it in his tests at Ardrossan, Scotland, in December, 1921, when he proved its value by copying signals from about thirty amateur stations located in various sections of this country.—THE EDITOR.

time, no readily practical method of securing radio-frequency amplification on wavelengths below about 400 meters had ever been devised. During the war, both the French and the British Army and Navy gave considerable attention to this phase of the art, for the reason that communication between airplanes, destroyers, and division headquarters had to be carried on through the medium of short-wave radio telegraphy and telephony. It took but a little while to discover that where the higher frequencies were to be handled in the amplifier, the distributed capacities inherent to all amplifier coils, circuit wiring, vacuum-tube receptacles, and the elements of the vacuum tubes themselves, offered a rather serious barrier to further progress. The reason for this is evident when it is understood that even extremely small capacities offer a rather low-resistance path to high-frequency oscillations. The higher the frequency of the oscillations, the lower the resistance of the path offered by any given capacity (condenser). The capacity between adjacent wires, metal fixtures, the elements of the tubes, terminals, and the layers of the windings upon the radio-frequency transformers, were sufficiently large to induce the currents to pass through them rather than through the paths laid out for them. Under these circumstances only a very small percentage of the currents actually passed through the transformers or the vacuum tubes to perform their functions there. Result, no amplification, although the amplifier tubes and their connected circuits either singly or in groups frequently set up oscillations among themselves, causing a further blocking of the

amplifier or a great to-do of hissing and howling.

The British were the first to take the most obvious path, that of reducing to an irreducible minimum the capacities existing in the transformers, the connecting wires, and the vacuum tubes, as a result of which there was developed a class of vacuum tubes—very good ones, too—now quite generally used by British radio folks.

Armstrong, above mentioned, and even then well known, had none of these British tubes available. Yet, as a loyal American, and an important link in the communications system of our expeditionary forces, it behooved him to provide, with such American made equipment as was at hand, a means of performing this so urgently needed service. Perhaps his mental processes at that time were something like this.

“Radio-frequency amplification on long wavelengths is a practicable proposition. Radio-frequency amplification on very short wavelengths is not a practicable proposition with vacuum tubes and other material available. Why not, then, by virtue of a frequency changer, *change the wavelength from short to long prior to amplification; amplify it as a long-wave oscillation and detect it afterwards?*” Apparently that seemed reasonable enough and I doubt that it took him more than a few moments, not only to conceive the idea, but to lay his hands upon the medium which would enable him to make of the conception a practicality. At any rate, as nearly as available records show, it was but a very short time after his introduction to the problem before he actually had what he was pleased to call his

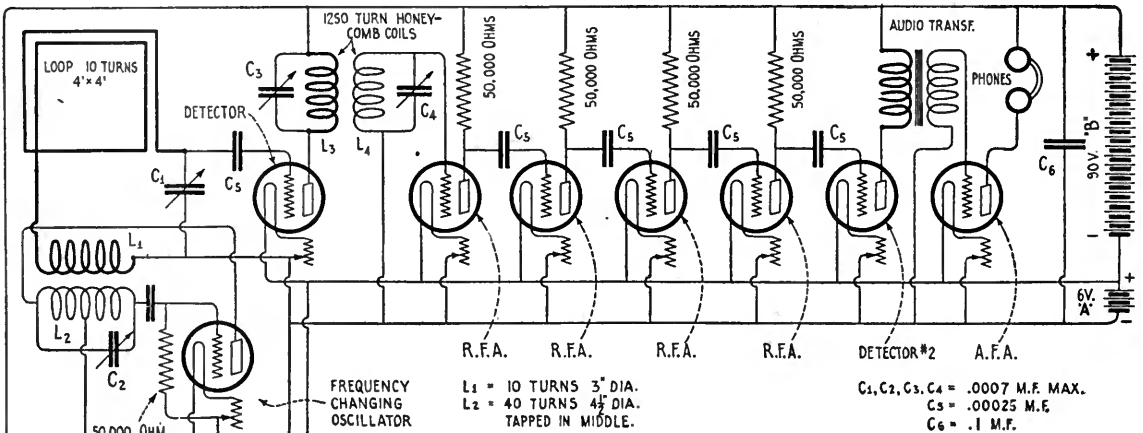

FIG. 1

The super-heterodyne circuit

super-heterodyne receiver, in action. It may be considered in one way unfortunate that before receivers of this type could be manufactured and put into service on the field, the armistice had been signed. But, as though the super-heterodyne were destined to assist in the making of history, it quickly found its way into the hands of a few fortunate, delighted, appreciative amateurs—created a worshipful enthusiasm—and was packed away to the dreary shores of Scotland. Here, during a short ten days' vigil, it showed its history-making calibre when it initiated international amateur radio communication.

As this is being written, considerable tinkering is being done with super-heterodyne receivers. The occasion for this tinkering is the transatlantic amateur tests of December, 1922. Before this reaches the reader's hands, there is little doubt but that the super-heterodyne will have shown again its great dependability as a receiver for sorting out, classifying, and recording extremely weak signals from great distances.

#### HOW IT WORKS

A THOROUGH understanding of the operation of the super-heterodyne is no difficult task. There are three actions which take place in the receiver in the following order: (1) a changing of the frequency of the incoming oscillation; (2) amplification of the oscillation at its new frequency; and (3) rectification (commonly considered as detection).

To the novice, the most mystifying function of the receiver combination is the frequency-changing action. This is simplicity itself. A detector tube has fed into it the incoming signal oscillations. This same detector has fed into it simultaneously oscillations which are generated at the receiving station by an oscillating vacuum-tube circuit. The circuits of the local vacuum-tube oscillator are so adjusted as to be either slightly lower or slightly higher in frequency than the incoming signal oscillations. The mixing of the two currents of different frequency in the detector tube gives rise to a new current of entirely different frequency in the output (plate) circuit of the detector tube which is known as the "beat-frequency current." By way of example in explaining the above, let us suppose that the detector circuit was tuned to receive signals on a wavelength of 200 meters. The oscillatory currents at this wavelength would be recurring

at a frequency of 1,500,000 times per second. Let us now adjust the local oscillator circuits so as to produce a frequency of 1,400,000 cycles per second. Under these circumstances the two currents differing in frequency by 100,000 cycles per second would re-act one upon the other in the circuits of the detector, so as to produce the "beat frequency" above mentioned, which would be equal to the difference of the two initial frequencies. This frequency-changing method was devised by Professor R. A. Fessenden, an American, and is known as the heterodyne method. Now, a frequency of 100,000 cycles per second corresponds to a wavelength of 3,000 meters. As mentioned above, there is no great difficulty encountered when alternating currents having frequencies as low as 100,000 cycles per second are to be amplified. Three, five, seven or even nine stages of radio-frequency amplification may be used with complete success if a few necessary precautions are taken. Subsequent to this amplification, a rectifier tube (detector) receives the amplified energy, rectifies it, and, if desired, passes it on to a second amplifier in order that the volume of the now audible signals may be increased.

A review of the foregoing explanation and reference to Figure 1 will quickly show that in its usual form, the super-heterodyne receiver is exceedingly easy to tune. There are only two prime adjustments. One controls the

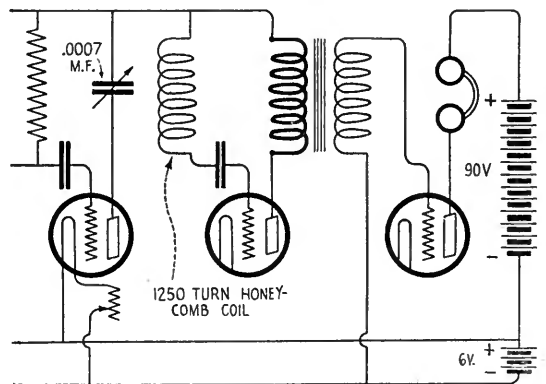
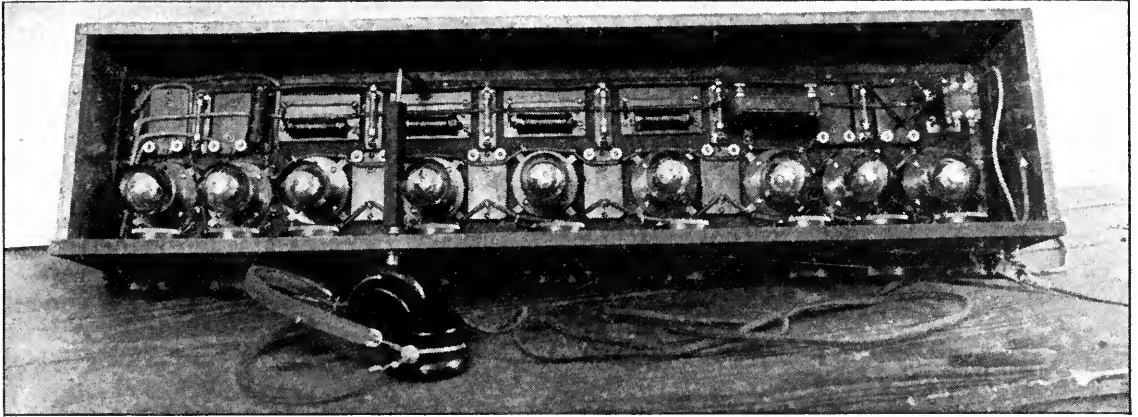

FIG. 2

wavelength of the "collector" or antenna circuit, while the other controls the wavelength (or frequency of oscillation) of the vacuum-tube oscillator circuit. Having set the one at the desired wavelength, it is only necessary to adjust the other until the dif-



THE SUPER-HETERODYNE RECEIVER

The walls of the cabinet are lined with copper sheeting, and the joints between sheets are carefully soldered

ference of their frequencies is equivalent to that frequency for which the amplifier itself is suited. The tuning of the circuits in the *output* side of the first detector tube and the input side of the amplifier are set once and for all and no change need ever be made in them.

## REFINEMENTS WHICH COUNT

IN FIGURE 2 it will be noticed that the output circuit of the amplifier is also tuned to the frequency of amplification. This serves in great measure to stabilize the action of a multi-stage amplifier of this type, as indicated by the fact that when resort is had to this expedient it becomes immediately possible to add two more stages of radio-frequency amplification before reactions in the amplifier circuits have reached the point where any great pains need to be taken to shield the various stages of the amplifier to prevent self-oscillation. Having guarded against self-oscillation of the amplifier, no matter by what method, advantage may be taken of the possibilities which lie in the regenerative action so closely allied with its tendency toward oscillations. Prior to the actual setting up of oscillations in any vacuum-tube circuit, considerable amplification of the signal which may be present results from the regenerative action inherent in the tendency toward oscillations. Control may be had over this tendency by utilizing a minute capacitive coupling between the output circuit of the last amplifier tube and the input circuit of the first amplifier tube. This usually takes the form of an exceedingly small, carefully shielded, variable condenser, as indicated in the figure above mentioned. Having taken these steps, the amplifier itself

will be working at or very close to maximum efficiency.

The third and final step in bringing the super-heterodyne receiver up within striking distance of the theoretical ideal is to produce in the circuits of the first detector tube a regenerative action upon the initial currents (the incoming signal currents). Not until this has been attempted do the complications of the circuits as a whole become apparent to the operator. But, to those who are skilled in the handling of regenerative circuits and multi-stage amplifiers this does not act as a deterrent. To the novice even, I should suggest that this method be tried, because a considerable and greatly-to-be-desired building up of the initial feeble currents results.

## CONTINUOUS-WAVE RECEPTION

AS TREATED thus far, the super-heterodyne receiver will not act as a receiver of continuous-wave (undamped) signals except under certain conditions of advancement where regeneration of initial

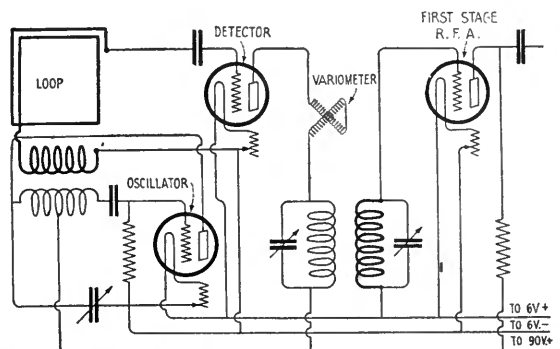

FIG. 3

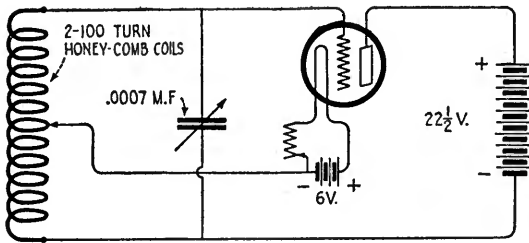

FIG. 4

An oscillator for continuous-wave reception

frequencies is being effected, and usually then in an unsatisfactory manner.

A simple and by far the most effective method of procuring audible reception of continuous-wave signals is to set up still another vacuum-tube oscillator (Fig. 4) *in the vicinity of the amplifier circuits*, this oscillator being so adjusted as to frequency that a second "beat frequency"—this time an audible one—is produced. In the case which we considered above, where the amplification frequency was 100,000 cycles, the practice would be to set the second oscillator so as to generate a frequency of 100,500 cycles. The "beat frequency" then produced would be an audible one, i.e., 500 cycles, which would give a note having a pitch just slightly lower than that heard when the middle C is struck on the piano. Having set this oscillator to produce the 500-cycle tone, it need not be changed, regardless of changes which may be made in the wavelength setting of the receiver. For, it will be remembered, the amplifier has passed to it only currents which have a frequency of 100,000 cycles.

In actual practice, it is found impractical to set the beat note oscillator at 100,500 cycles, because, unless great pains are taken to shield

the beat-note oscillator carefully, the oscillations produced by it—even though they be very feeble ones—tend to paralyze the action of the amplifier. This problem may be easily solved by setting the oscillator at double the wavelength (half the frequency). There always exists, in the circuits of the oscillator, harmonics of the true oscillation. If the fundamental oscillation (100,500 cycles) is so strong as to paralyze the action of the amplifier, either the third or fifth harmonic will usually be found of proper strength to give the desired signal without paralysis of the amplifier tubes. The third harmonic is obtained by setting the oscillator at double the wavelength of amplification (6,000 meters or 500,000 cycles, approximately). The fifth harmonic is obtained by setting the oscillator at four times the frequency of amplification (12,000 meters or 250,000 cycles). Figure 3 shows this last arrangement. Attention is called to the fact that the beat note oscillator need be no nearer to the amplifier than about four to six feet.

Care in selecting and placing the tubes available for use in the super-heterodyne is of great importance. That great thing which is to be desired is *silence* in the amplifier. Noises due to tube faults are a great deterrent. Tubes which show inclination toward noisiness should be used in the latter stages of the amplifier if at all.

I have found many users of multi-stage amplifiers complaining about tube noises which were not tube noises at all. The noises which I have in mind were due to poor connections in the battery circuits. In fact, a poor connection at any point will cause noise, but it seems that the most common cause is the existence of carelessly made connections

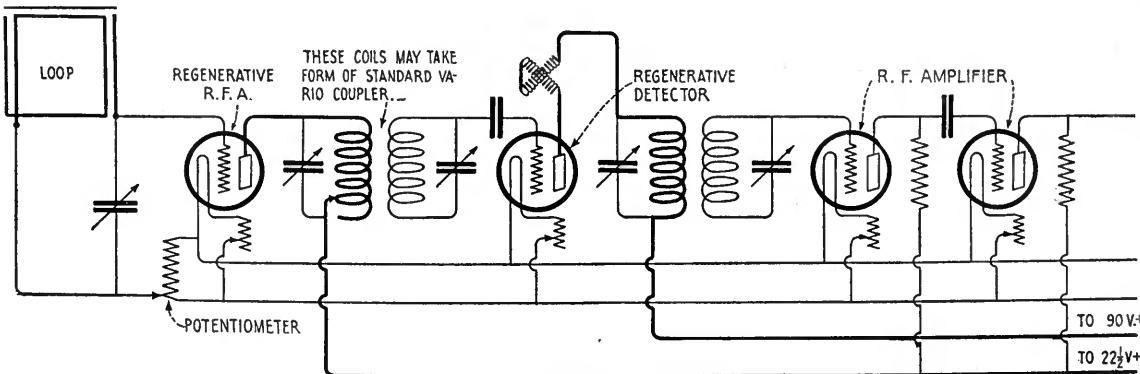

FIG. 5

The super-heterodyne circuit with tuned radio-frequency amplification



PANEL VIEW OF THE SUPER-HETERODYNE RECEIVING SET

There is a separate rheostat provided for controlling the filament voltage of each tube

in the filament-lighting circuit or to the filament-lighting battery itself.

Further, it is frequently necessary to set an amplifier of this character on rubber cushions so that mechanical shocks due to movements within the room will not cause a "ringing" of the tube elements. Preferably, each tube should have its own individual shock absorber. This enables work upon the amplifier while in operation without great noise in the headphones due to handling units in the circuit.

The final touch to be given to the super-heterodyne consists in adding to it a stage of tuned radio-frequency amplification. Of course this still further complicates tuning. The gain in signal strength is fairly well worth while, however, and the expedient will be adopted by all true experimenters. This arrangement is shown in Figure 5.

Having added this improvement, the user can be certain that he is in possession of the most sensitive radio receiver ever devised.

## If You are Thinking

*Of submitting an article to RADIO BROADCAST, you may save yourself and the editors time and trouble by considering the following notes as to what we want and what we cannot use:*

### WE WANT:

*True accounts of the uses of radio in remote regions.*

*Short, true stories of adventures in which radio played an important part: unusual and interesting occurrences to you or your acquaintances.*

*Clear explanations of new or especially effective circuits or uses for apparatus.*

*Concise and logical discussion of some important problem or phase of radio, whether in the field of broadcasting, constructing, operating, buying or selling; or of reading or writing that has to do with radio.*

*True accounts, of some particular interest, relating "What Radio Has Done For Me."*

*Humor, when the object is not merely to appear funny, but to present some phase of radio in an attractive, amusing way. The same applies to drawings.*

*Clear, unusual photographs are always in order, as are good circuit diagrams.*

*A liberal rate is paid for material used.*

### WE CANNOT USE:

*Fiction, unless it deals in a striking way with some subject of interest to those interested in radio.*

*Articles or illustrations to which RADIO BROADCAST would not have the exclusive rights.*

*The best way to do is to read through several numbers of the magazine to get an idea of the various kinds of articles we publish.*

# How Far Have You Heard on One Tube?

64,660 is the Best Aggregate Mileage Record So Far. Notes on Tuning. What Others Have Done. The End of the Contest February 1st

## FEELING THE NATION'S PULSE

By RUSSELL SHEEHY

Mr. Sheehy, who has piled up an aggregate mileage of 63,860 of stations 150 to 2050 miles distant, literally has his fingers on the nation's pulse at his home in Newfields, New Hampshire. He listens-in on Dallas, Texas; New Orleans, La.; Tampa, Fla.; Denver, Colo.; Wichita, Kansas; Havana, Cuba; Ensenada, P. R.; Toronto and Montreal, Canada; Lincoln, Nebraska; Chicago, Ill.; Kansas City, Mo., Louisville, Ky., and other stations too numerous to mention.

He has reduced the operation of his set to a logical set of rules which should be of value to others in securing similar results.—THE EDITOR.

USING the circuit shown in Figure 1, I have been able to hear, from my home in New Hampshire, most of the Eastern, Southern, Western and Southwestern stations on a single tube. Most of them come in very clear and loud when conditions are not extremely bad, and it is generally possible for me to hear the entire programme from any one of the stations on the list appended. Many sets are capable of picking up one or two selections from these stations, but somehow or other they cannot be held. With the circuit I am employing, after once a station has been found, it may generally be held until you desire to tune in another.

My entire outfit is home-made, including the variocoupler which is wound with 35 turns on the stator and 35 on the rotor. No switch points or taps are used. After experimenting with different values, I found these values suited my aerial, the series condenser being .001 mfd. in the aerial circuit.

The only trouble I had with this circuit was in the paper condensers and I strongly advise the use of mica condensers and tubular leaks in the grid circuit. The .001 mfd. variable condenser across the phones and batteries may be substituted by a .002 mfd. fixed condenser or sometimes on near-by stations by a .005 mfd. fixed condenser. In the last instance, the signal strength is very materially increased.

The entire circuit is quite simple of operation and most of the tuning is done with the condenser in the aerial circuit and the tickler con-

trol. A filament volt-meter or ammeter is a good addition, and after once finding the plate and filament voltages, this part of the tuning is almost eliminated from the routine. I operate my filament on 4.4 volts and very rarely have to change it. With most of the detector tubes I have tried, the best B battery voltage is 18. Of course, this has to be found by experimenting with your particular tube. I have found that two potentiometers are quite an asset when long distance signals are desired. In this connection, the variable condenser across the phones and batteries is also very helpful. The potentiometer with the slider grounded at the correct position of the tickler may cause the tube to oscillate, by moving it toward the negative side, and it is just before this point of oscillation that signals are clearest and loudest. The set is operating at its best when you find that moving the condenser either way produces no oscillation, but there is a sort of "purr" on each side of your signal.

The simplest method for beginning the operation of this set is to set your tickler at about 10 and move the condenser until a signal is heard (this is taking it for granted that you are on the correct switch point for the broadcasting wavelengths if you are using a variocoupler with a tapped primary.) If you find a squeal on either side of your signal, loosen the tickler, that is, bring it back toward zero, moving it very slowly, however, and the distance you will have to move it depends on the strength of the signal. If it is quite loud, move



it three or four degrees, whereas if it is weak, a fraction of one degree may sometimes suffice. Every time you move the tickler it is necessary to readjust the condenser in the antenna circuit, going back and forth until the signal is produced without any interfering noises. If no signal is heard when the condenser is moved, it is generally necessary to tighten the tickler coupling, moving it up to 15 or 20 and reducing it according to the previous routine after a signal has been picked up.

This outline of operation may seem rather long-winded, but it takes much longer to tell about it than it does actually to carry it out, and once you become accustomed to your set you know just about where to set the tickler at the start so that it is generally necessary only to move the condenser in order to receive the desired signals. If you find that you get a station just on the point of oscillation and there is a click and then no signal left when you move the condenser, you will have to try different values of filament current and B battery voltage. It took me two days to find the proper places for these two variables with my last tube, but this particular point is well worth the time spent in securing it, for it stays there very well afterward.

With mica condensers and tubular grid leaks, there is nothing to pull the set apart for when the signals are not coming in particularly well on some night. After testing the A and B batteries and finding them all right you had better leave the set alone and call it a "bum" night and wait until the next night when you will be surprised at the way it works. Give it a fair chance. When your automobile goes bad you don't immediately take the engine apart, take the gas tank off, or see what the carburetor is made of. Of course not. Give the radio receiver a chance. Look at some simple things like loose connections or low batteries first before you take condensers apart.

With the two potentiometers across the A battery, it is a good plan to put a switch on one side of the line from set to battery and then there is no drain such as would otherwise exist.

Don't turn your filament right off. Turn it off a little at a time.

Don't put up a length of telephone wire when you can get some aerial wire for a dollar or less.

Keep your aerial well insulated on both ends and don't spend one month on a set and one hour on an aerial and ground system. They have tasks to perform which are as important as those of the set itself.

If these instructions are carefully followed, you may rest assured that if you are getting poor signals some night there is no need of going over to your neighbor's, as he will be in the same boat.

My ground system is rather unique, and I have found it better than those ordinarily employed. It is a single wire directly under the single-wire aerial (125 ft. long), buried about a foot in the earth, at the end of which are extended six wires about 50 feet in

a fan shape also buried about a foot and extending beyond the aerial. My aerial runs east and west with the lead-in on the western end. I couldn't find much advantage in direction, but think that the direction from which you are to receive should be reasonably free of objects that are near, like trees and houses. Try to have a clear view in the direction of the transmitting stations considering yourself as standing on the top of the aerial.

Don't run No. 24 wire to your A battery, use No. 14 at least.

This set is really selective and sharp, especially since I have built an 8-inch cage lead-in. It is sometimes possible to leave the antenna condenser set and tune in three or four different stations by properly manipulating the tickler.

The following is the list of stations heard that are 150 or more miles distant:

#### THE CONTEST ENDS FEBRUARY 1st

Unless your aggregate mileage exceeds 50,000, do not include a description of your receiver, merely send in a circuit diagram accompanied by a list of the stations you have heard with the mileage opposite each. If a diagram of the receiver you are using has already appeared in RADIO BROADCAST, it is not necessary to do more than refer to the page of the issue in which it appeared.

First consideration will be given to descriptions accompanied by photographs, and the cost of building the receiver will also figure in judging a report.

The final reports in the "How Far Have You Heard?" contest will appear in RADIO BROADCAST for April. *Material received later than February 1st cannot be considered.*—THE EDITOR.

STATION	MILES DISTANT
WFAA —Dallas, Texas . . . . .	1650
WRR —Dallas, Texas . . . . .	1650
WCAR —San Antonio, Texas . . . . .	1860
WEAY —Houston, Texas . . . . .	1700
WBAY —Fort Worth, Texas . . . . .	1650
WAAB —New Orleans, La. . . . .	1450
WGAQ —Shreveport, La. . . . .	1500
WEAT —Tampa, Fla. . . . .	1300
WHAD —Milwaukee, Wisconsin . . . . .	885
WHA —Madison, Wisconsin . . . . .	960
KDZU —Denver, Colorado . . . . .	1835
WAAP —Wichita, Kansas . . . . .	1470
WDAJ —College Park, Ga. . . . .	1000
WGM —Atlanta, Ga. . . . .	1000
WSB —Atlanta, Ga. . . . .	1000
PWX —Havana, Cuba . . . . .	1600
WGAD —Ensenada, P. R. . . . .	1700
BFGA —Toronto, Canada . . . . .	450
CFC A —Toronto, Canada . . . . .	450
CKAC —Montreal, Canada . . . . .	225
CFCF —Montreal, Canada . . . . .	225
WGAT —Lincoln, Nebraska . . . . .	1400
WGAS —Chicago, Illinois . . . . .	900
WDAP —Chicago, Illinois . . . . .	900
KYW —Chicago, Illinois . . . . .	900
WMAQ —Chicago, Illinois . . . . .	900
WWJ —Detroit, Mich. . . . .	650
WCX —Detroit, Mich. . . . .	650
WHB —Kansas City, Mo. . . . .	1300
KSD —St. Louis, Mo. . . . .	1100
WLK —Indianapolis, Ind. . . . .	840
WOH —Indianapolis, Ind. . . . .	840
WJAX —Cleveland, Ohio . . . . .	600
WHK —Cleveland, Ohio . . . . .	600
WFO —Dayton, Ohio . . . . .	750
WLW —Cincinnati, Ohio . . . . .	800
WAAD —Cleveland, Ohio . . . . .	600
WGAM —Orangeburg, S. C. . . . .	900
WBT —Charlotte, N. C. . . . .	800
WLB —Minneapolis, Minn. . . . .	1150
WAAL —Minneapolis, Minn. . . . .	1150

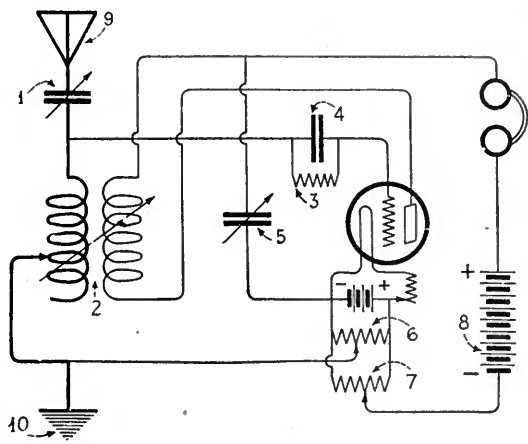
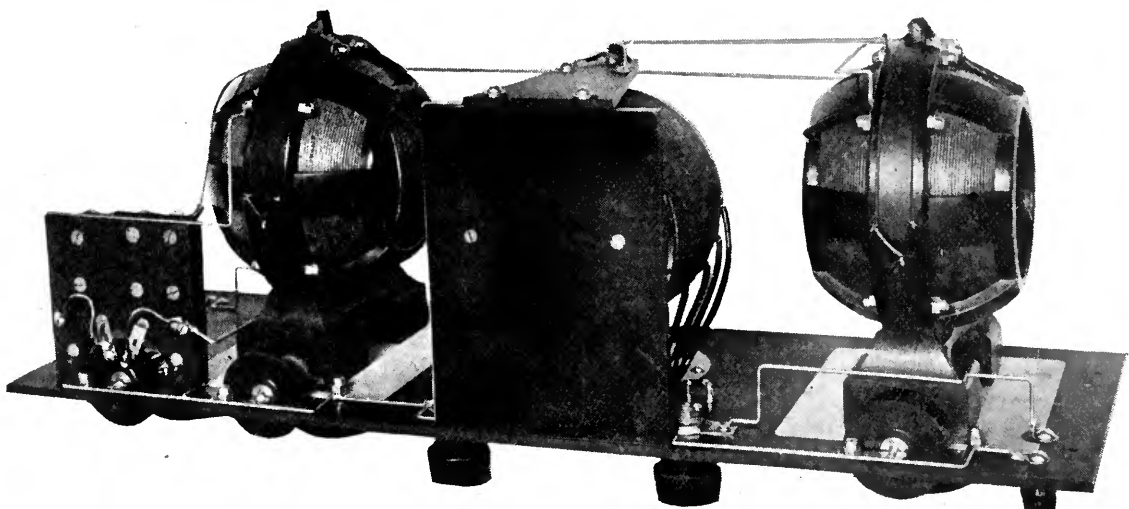

FIG. 1

- 1 Variable condenser of .001 mfd. capacity.
- 2 Any variocoupler of standard make, range 150 to 600 meters.
- 3 1-megohm grid leak.
- 4 Grid condenser of .0005 mfd. capacity.
- 5 Variable condenser of .001 mfd. capacity.
- 6 200-ohm potentiometer.
- 7 200-ohm potentiometer.
- 8 B battery, 16½ to 22 volts, for UV200 tube.
- 9 Antenna 125 feet long, 40 feet high, 7/22 stranded.
- 10 Counterpoise ground. Single wire 125 feet long, buried one foot deep, under the antenna

WBAU —Hamilton, Ohio . . . . .	850
WOC —Davenport, Iowa . . . . .	1050
WOI —Ames, Iowa . . . . .	1200
WGF —Des Moines, Iowa . . . . .	1200
WHAS —Louisville, Ky. . . . .	870
WBAZ —Richmond, Va. . . . .	550
WSN —Norfolk, Va. . . . .	550
NOF —Washington, D. C. . . . .	450
WMU —Washington, D. C. . . . .	450
KPM —Washington, D. C. . . . .	450



A WELL-DESIGNED 3-CIRCUIT TUNER

Of the type that has been in service for several years. Those who build their own will do well to attempt the same class of workmanship

WHAV—Wilmington, Del. . . . .	350
WGL —Philadelphia, Pa. . . . .	315
WIP —Philadelphia, Pa. . . . .	315
WOO —Philadelphia, Pa. . . . .	315
2CDT —Philadelphia, Pa. . . . .	315
WCAU —Philadelphia, Pa. . . . .	315
3XW —Parkersburg, Pa. . . . .	280
WBAK —Harrisburg, Pa. . . . .	375
WBAX —Wilkes Barre, Pa. . . . .	250
WIAN —Allentown, Pa. . . . .	275
WGAL —Lancaster, Pa. . . . .	350
WJT —Erie, Pa. . . . .	480
KQV —Pittsburgh, Pa. . . . .	500
KDKA —Pittsburgh, Pa. . . . .	500
WJAS —Pittsburgh, Pa. . . . .	500
WJZ —Newark, N. J. . . . .	240
WOR —Newark, N. J. . . . .	240
2XA1 —Newark, N. J. . . . .	240
WAAM —Newark, N. J. . . . .	240
WRP —Camden, N. J. . . . .	315
2XJ —Deal Beach, N. J. . . . .	250
WEAM —N. Plainfield, N. J. . . . .	225
WIAD —Ocean City, N. J. . . . .	225
WBAN —Paterson, N. J. . . . .	225
WAAT —Jersey City, N. J. . . . .	225
WCAN —Jacksonville, Fla. . . . .	1110
WIAO —Milwaukee, Wisconsin . . . . .	885
WGY —Schenectady, N. Y. . . . .	150
WGR —Buffalo, N. Y. . . . .	400
WRL —Schenectady, N. Y. . . . .	150
WHAM—Rochester, N. Y. . . . .	350
WFAQ —Waterford, N. Y. . . . .	180
WRW —Tarrytown, N. Y. . . . .	180
WMAK—Lockport, N. Y. . . . .	385
WCAB —Newburg, N. Y. . . . .	200
KDOW—S. S. America, at sea . . . . .	750
WCAX —Burlington, Vt. . . . .	150
WHAZ —Troy, N. Y. . . . .	150

Aggregate mileage: 63,860

THE "CARPET OF BAGDAD"

ANOTHER simple application of the single-circuit regenerative receiver is found in Fig. 2 on page 340. It was brought to our attention by Mr. W. McMiller of the Southern Methodist University, Dallas, Texas. In describing the operation of this circuit, which Mr. W. M. K. Young of Kansas City, Mo. calls the modern "Carpet of Bagdad," Mr. McMiller says: "During the summer months when so many fans were complaining of the so-called static, I was receiving Kansas City, St. Louis, Jefferson City, Denver, Cincinnati, Atlanta, Houston, San Antonio and other stations a long distance off quite regularly. Static has been the very least of my troubles. Since the cooler weather has set in, I have been able to receive up to 1400 miles. I have been able to hear 128 different stations in 27 states as well as Cuba and Mexico. It is also possible for me to hear

foreign countries by employing various sized coils according to the wavelength desired.

"One of the most remarkable features about this set is that it is quite simple to tune out stations that are not wanted, and another very attractive feature is that the materials necessary may be had for a few dollars.

Mr. McMiller says that he has discarded two variometers and a variocoupler and a two-stage audio-frequency amplifier in favor of the very small outfit he has described.

In using the same circuit, Mr. Young says: "My 'Carpet of Bagdad' and I started on a journey one evening, and I will give a description so that you may judge the value of the design. My stops were all over 500 miles from my starting point, the farthest being 1,140 miles by air line. I had not been long on my way when the "Voice of the South" from The Atlanta Journal stopped me with the well-known melodies of the Southland. Continuing, I soon heard a voice saying, 'This is WFAA, the Dallas News, and then I heard 'In the Garden of My Heart' being sung by Mr. Losier. Only a short distance from there I heard WBAP, the Fort Worth Star Telegram. These old songs from the Southland were beautiful and I hated to leave them, but adventure was in the air and I had to continue.

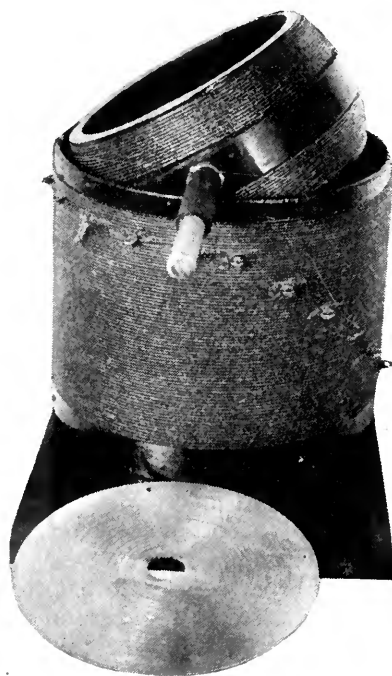

A SUITABLE VARIOCOUPLER  
For broadcasting or amateur reception, with its metal shield which reduces body capacity effects

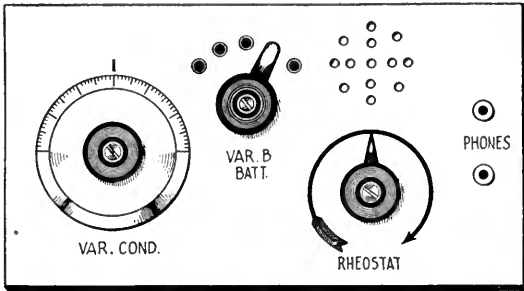

MR. MCMILLER'S PANEL ARRANGEMENT  
Controlling the B battery from the panel is a great convenience

So back to the North I went to get a serenade from WLAG, Minneapolis, as I passed over on the way to KDKA at Pittsburgh and then on to WRL, Union College at Schenectady, N.Y. This completed the Eastern part of my trip, and I started back, stopping at Indianapolis with the Hatfield Electric Company and hearing WWJ, the Detroit *News*, while I waited. My next and last stop was back in the Central West, where the mountains hold a station designated as DN4 operated by the Colorado National Guard at Denver, a beauty spot 640 miles from my home.

"My first evening's journey is completed and only a memory now, but while I have lengthened my trips and have spent more time at each of my stops, my first evening will always be the best that I ever took because of the thrill and enjoyment it gave me."

THE STANDINGS OF CONTESTANTS PREVIOUSLY UNMENTIONED

THE single-circuit regenerative receiver seems to be leading in the contest, and the great number of letters we have received and the great distances being covered have made it necessary for us to increase the minimum number of aggregate miles to 15,000.

Mr. Leonard B. Robinson, 537 Hillside Ave., Glen Ellyn, Illinois has an aggregate mileage of 30,430.

Mr. R. A. Riggs of Vevay, Indiana has an aggregate of 22,045 miles.

Mr. George J. Schottler of Dexter, Minnesota aggregates 16,790 miles.

We rather expected to find that the users of the Rheinartz circuit would stand well to the front in this contest, but the best single distance made by any contestant using that circuit is 1,325 miles, and there is no aggregate mileage as high as 15,000.

With a standard loose-coupler, Mr. Edwin H. Sands, State Housing Commissioner at Des Moines, Iowa, has been able to pile up an aggregate mileage of 25,835, this with a non-regenerative receiver.

The Aeriola Seniors are standing up very well. Mr. W. J. Buckley of Fairfax, Oklahoma has an aggregate mileage of 19,030. His best single jump is 1,425 miles.

Mr. A. B. Johnson, Garfield Ave., DuBois, Pa. has an aggregate mileage of 17,375 with the best single jump of just 1000 miles.

The best report from Aeriola Senior operators we have received so far comes from Mr. A. R. Ackerman, who has received directly from Los Angeles at his home in Nashville, Tennessee. This is 1800 miles.

Mr. L. W. Carlisle, of Lisbon, North Dakota has come so close to the aggregate mileage necessary that we just can't overlook him. His aggregate is 14,795.

STANDARD REGENERATORS

REPORTS from users of standard regenerative receivers are fairly good. John R. Corrish of Bridge St., Monson, Mass. aggregates 18,465 miles with 1,500 miles as his best single jump.

Mr. C. L. Hobart of Grant's Pass, Oregon reports an aggregate of 45,580, his best single jump being 1,275 miles.

VARIOMETER REGENERATORS

THE best report from the users of a variometer regenerator receiver is from Maury Simmons, 2700 Darien St., Shreveport, La., whose aggregate is 36,250 with 1300 miles as his best single jump.

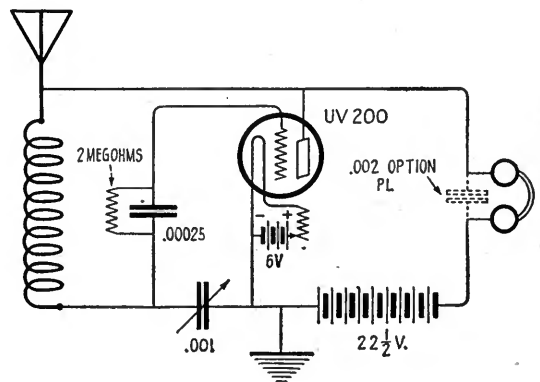

FIG. 2

The "Carpet of Bagdad" circuit. When the set is adjusted, all tuning is done with the variable condenser

# 55,000 Miles on a Dry-Cell Tube

## ANOTHER BEGINNER'S STORY

By HARDING GOW

WE SPENT last summer on Orcas Island of the San Juan group up in the northwest corner of the United States. Of course we took a crystal set along, but as that limited us to one station it naturally followed that we had to have a tube set. At that time I did not know the difference between a variometer and a grid leak, so I came down to the Seattle Radio Show in search of information and material.

I selected a tube which had just been put on the market and which required only one dry cell for the A battery, inasmuch as there was no way of charging storage batteries at East Sound, and decided on spider-web coils because I had obtained good results with them on a crystal set, and also because there seemed to be practically no data obtainable on them and I was curious to try out their possibilities. I may add that I have never regretted the choice.

In first assembling my apparatus, I followed the conventional custom of compactness and got the condensers too close together. I tried shields between them and also a panel shield for body capacity but this seemed to me to reduce materially the signal strength, and in working distant stations on one tube, the tiny bit of energy absorbed by the shields may decide whether the voice of that fellow 1,800 miles away comes in clearly or as a confused murmur. So I pulled the set to pieces (a frequent occupation at first) and spaced the condensers well apart in a larger cabinet, mounting the coils on the ends of four-inch brass rods to get them away from the condensers. Then I began to get results.

The final assembly is shown in the photograph, which I am free to admit could not be called handsome, but the way it reached out and gathered in the distant stations was a constant surprise and delight.

The hook-up is the ordinary three-circuit regenerative type except that I used a variable condenser across the B battery and phones, and another across the tickler coil, and find them of great value in tuning the plate circuit without changing the tickler coupling, and they also bring out the tone of both voice and music.

The secondary condenser is sensitive to body capacity, but with the type of vernier handle shown it is possible to avoid annoyance from this cause.

For the values given, the primary and secondary condensers work best on about the same reading. I usually set them at 35° to 40° and pick up the stations by varying the primary coupling, maximum signals being obtained by adjustment of the plate condensers and the primary vernier.

The set is extremely selective. I think the most surprising feature to my wife was that she could shift from Fort Worth, Texas, to Calgary, Alberta, by moving the primary coil perhaps an inch!

From six to ten stations could be tuned in and out in this way without resetting the condensers, and I frequently was able to pick up both ends of test conversations between stations. One night I heard Calgary, CFCN, calling Wallace, Idaho, KFCC. I listened to them for some time when KFAY at Medford, Ore., came in, KDZZ at Everett, KMO at Tacoma, and 7X1 at Portland, all by shifting the primary coil, and I seemed to hear them better

### On Standardizing Radio Equipment

Commander Stanford C. Hooper, U.S.N., is the man who suggested the formation of an American organization to maintain our position in radio communication. The Radio Corporation of America is the result. Commander Hooper has entire charge of the Navy's intricate radio communication system and is head of the Radio Division of the Bureau of Steam Engineering. He has some very constructive views on standardizing equipment and is preparing for RADIO BROADCAST an article on this important subject, which will appear in the March number.—THE EDITOR.

than they heard each other as several of them asked the others to repeat.

I think one of the best records was our hearing KFAU at Boise, Idaho, 475 miles one night when they happened to be using *only 5 watts*.

There is a little mountain, "Constitution," due east of us about three miles, or rather I should say that we were due west of it, and I believe it blocks the eastern stations to some extent, as we did better to the southeast, and the world turns the wrong way for us to pick up the eastern stations after things quiet down at night as they can do with us.

I have not found my WD -11 tube critical as to filament voltage, and I get best results by using 39 volts on the plate.

Here are some values for my equipment:

Coils wound on  $\frac{1}{8}$ " fibre frames 6" in diameter with 2" centres, 15 sections, frames being moisture proofed with fixture lacquer before winding. Coils mounted on cartridge fuses, swung in fuse clips.

- L-1 60 turns No. 23 DCC wire
- L-2 70 turns No. 23 DCC wire
- L-3 50 turns No. 23 CDC wire
- C-1 43-plate plus 3-plate vernier
- C-2 9-plate plus 3-plate vernier
- C-3 23-plate
- C-4 5-plate
- Grid condenser, .00025 mf. (no grid leak)
- Antenna, single wire 35 ft. high, top 110 ft., lead-in 40 ft.

STATION	LOCATION	DISTANCE FROM EAST SOUND, WASH.
CHBC	Calgary, Alberta, Canada	445
CHCQ	Calgary, Alberta, Canada	445
CFCN	Calgary, Alberta, Canada	445

KFCB	Phoenix, Ariz.	1220
CJCB	Nelson, B. C.	265
Catalina	San Pedro Radio Link	1070
KUY	El Monte, Cal.	1060
KLP	Los Altos, Cal.	815
KHJ	Los Angeles, Cal.	1070
KYJ	Los Angeles, Cal.	1070
KOG	Los Angeles, Cal.	1070
KWH	Los Angeles, Cal.	1070
KFI	Los Angeles, Cal.	1070
KZM	Oakland	770
KLX	Oakland	770
KDYN	Redwood City, Cal.	800
KFBK	Sacramento, Cal.	725
KVQ	Sacramento, Cal.	725
KFBC	San Diego, Cal.	1185
KDPT	San Diego, Cal.	1185
KDYM	San Diego, Cal.	1185
KRE	San Francisco, Cal.	770
KFDB	San Francisco, Cal.	770
KUO	San Francisco, Cal.	770
KSL	San Francisco, Cal.	770
KDN	San Francisco, Cal.	770
KPO	San Francisco, Cal.	770
KLS	San Francisco, Cal.	770
KDZX	San Francisco, Cal.	770
KQW	San Jose, Cal.	805
KJJ	Sunnyvale, Cal.	800
BF4	Denver, Col.	1100
DD5	Denver, Col.	1100
KLZ	Denver, Col.	1100
KFAF	Denver, Col.	1100
WSB	Atlanta, Ga.	2300
KFBJ	Boise, Idaho	475
KFAU	Boise, Idaho (10-Watt)	475
KFAN	Moscow, Idaho	310
KFCC	Wallace, Idaho (10-Watt)	340
KYW	Chicago, Ill.	1840
WOC	Davenport, Ia.	1700
WHB	Kansas City, Mo.	1600

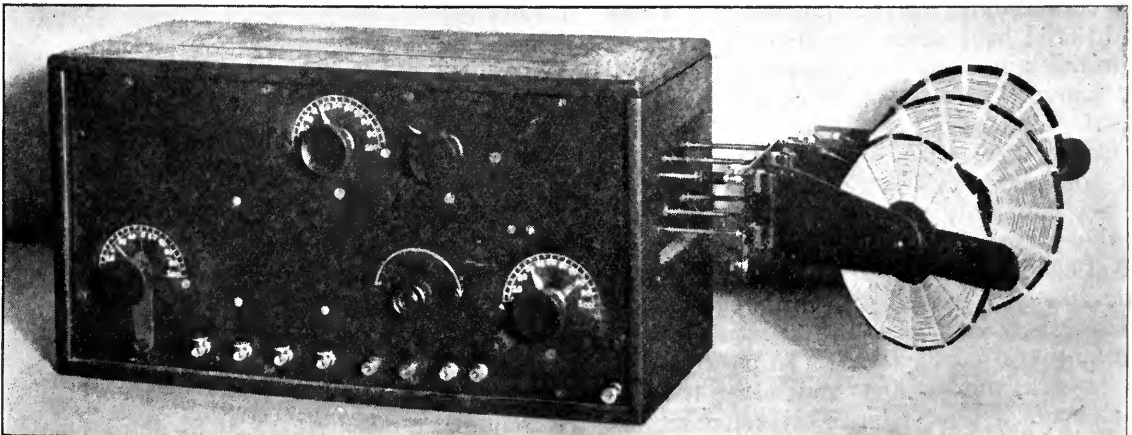

MR. GOW'S INTERESTING HOME-MADE RECEIVER

Showing the three spider-web coils mounted outside the cabinet in order to get them away from the condensers

KFAP	Butte, Mont. . . . .	525
KDYS	Grest Falls, Mont. . . . .	560
KFBB	Havre, Mont. . . . .	625
7XD	Polytechnic, Mont. . . . .	325
KDZK	Reno, Nev. . . . .	660
KFAS	Reno, Nev. . . . .	660
CJCG	Winnipeg, Man. . . . .	1175
KFBM	Astoria, Ore. . . . .	190
7YJ	Corvallis, Ore. . . . .	290
KDZJ	Eugene, Ore. . . . .	325
KFAY	Medford, (Listed Central Point)	450
KYG	Portland, Ore. . . . .	225
KGW	Portland, Ore. . . . .	225
KGG	Portland, Ore. . . . .	225
KFAB	Portland, Ore. . . . .	225
7X1	Portland, Ore. . . . .	225
KQY	Portland, Ore. . . . .	225
7XS	Portland, Ore. . . . .	225
WEAY	Houston, Tex. . . . .	2000
WFAA	Dallas, Tex. . . . .	1800
WBAP	Fort Worth, Tex. . . . .	1780
KZNY	Salt Lake, Utah . . . . .	780
KDYL	Salt Lake, Utah . . . . .	780
BQ3	Vancouver Barracks, Wash. . . . .	225
KZV	Wenatchee, Wash. . . . .	150
KDZI	Wenatchee, Wash. . . . .	150
KFBF	Walla Walla, Wash. (new Sta.)	285
KFV	Yakima, Wash. . . . .	175

55,150

The stations listed have all been positively identified both by call letters and name, and all

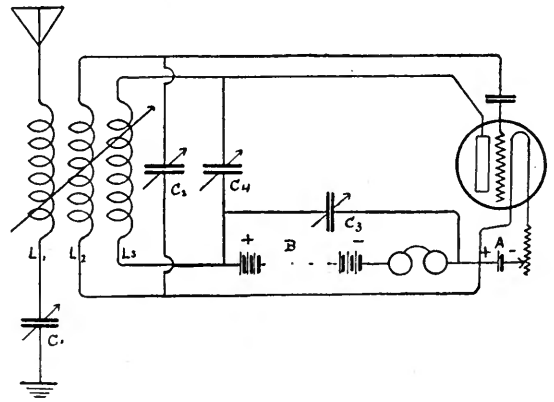

THIS IS THE CIRCUIT USED BY MR. GOW  
On one tube, he has heard stations 2000 miles from his home

of the "W" stations and almost all of the remainder have been heard by my wife, as we use two headsets, the only distant station on which I have not her check being KYW.

It was hard to leave out WEAR, Baltimore, 2,450 miles, of which I had the call clearly, but Bellingham started up on so nearly the same wavelength that I was unable to verify the name.

The summer static was bad until well into September, so most of the stations were listed from Sept. 10th to November 13th when we left East Sound.

## Concerning Mrs. Hale's Lecture on Cancer

**I**N OUR October issue we called attention to the broadcasting of a lecture by Mrs. Annie Riley Hale on the subject of cancer treatment.

Mrs. Hale feels that some of the statements in that article are a personal reflection upon her. Our purpose was not to attack the character, the motives, or the education of Mrs. Hale in any way, and we wish to retract anything that could be so construed, and to express our sincere regret for it. The object of the article was to remind the broadcaster of the duty he owes to the radio public to scrutinize with care anything he sends out which is calculated to affect people's decision and judgment, and especially so in matters affecting health and perhaps life itself. We are not to be understood as modifying views which we expressed, but we are very sorry to have said anything that could be considered as a personal criticism of Mrs. Hale.—THE EDITOR.

# Notes on the "Parker" Circuit

By ZEH BOUCK

Since the publication in the December issue of RADIO BROADCAST of the circuit used by Mr. Parker in his remarkable reception, letters have been received from enthusiasts who, having achieved similar results, desire to improve their apparatus still further by the addition of amplifiers. Due to the unconventionality of the circuit, this presents something of a problem to our less experienced readers. Amplification, and other interesting possibilities of the circuit are covered in the accompanying article.—THE EDITOR.

REFER to the *Parker* circuit in order to designate the hook-up by a name already known to the readers of RADIO BROADCAST.\* Mr. Parker, however, was not the first to see the advantages of the hook-up, for receivers similar to his have been used by amateurs for some years, and no little original work on Mr. Parker's particular phase of the circuit was done by Mr. Walter J. Howell, at present Assistant Radio Inspector of the Second District, who initiated the writer into the possibilities of the receiver.

The diagram as previously given is not well adapted to audio-frequency amplification, using common A and B batteries for the detector and amplifier tubes. If the additional amplifying high-voltage batteries are added on the positive side of the detector B battery, more of them may be required than in other

regenerative sets, if the detector tube is operated on considerably less than the full voltage of the first block. This is because, in Mr. Parker's original circuit, any reduction of the detector plate voltage necessarily lowers that of the amplifier. On the other hand, if the additional batteries are placed on the negative side of the original block, the potential on the detector will be increased sufficiently to render the bulb inoperative; or, if the connection is made to the minus terminal of the first block, rather than to the tap, a portion of the high-voltage batteries will be short-circuited. These difficulties are obviated in Fig. 1, which shows the circuit adapted to a two-stage amplifier. It will be noted that the detector plate voltage is varied by tapping to a positive potential with the lower end of the variocoupler secondary, rather than by varying the connection between the B battery cells and the ground lead!

\*This circuit was described in the December number, pp. 114-117.

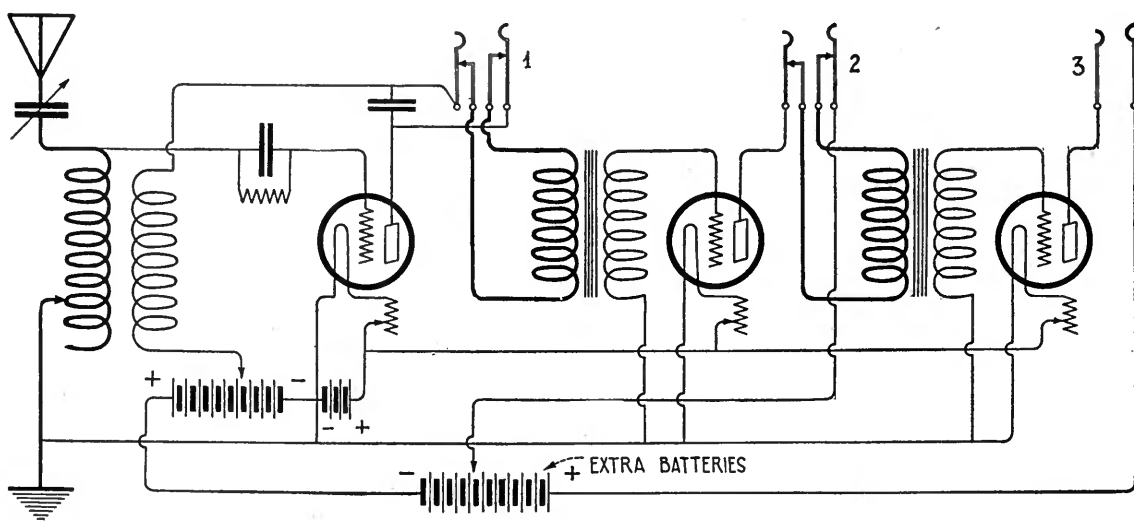
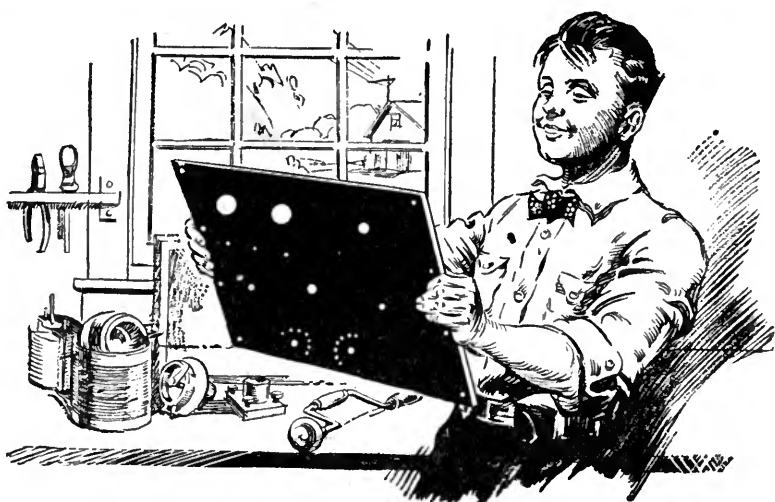

FIG. 1

Diagram of the "Parker" circuit, described in RADIO BROADCAST for December, used with a two-stage amplifier. Instead of varying the connection between the B battery cells and the ground lead, the detector plate voltage is varied by tapping to a positive potential with the lower end of the variocoupler secondary





## This Panel Will Improve Your Set

# CONDENSITE CELORON

**T**HE best panel made is none too good for your set. Dependable insulation is vital because it has a direct bearing upon the clearness and sensitivity of both transmission and reception.

Every thinking radio enthusiast certainly wants the highest type panel he can obtain and the surest way to get it is to insist upon Condensite Celoron.

This strong, handsome, jet-black material is not merely an insulating material—it is a radio insulation made to meet high voltages at radio frequencies. That is why it will give you greater resistivity and a higher dielectric strength than you will ever need.

Make your next panel of Condensite Celoron. It machines readily, engraves with clean cut characters and takes a beautiful polish or a rich dull mat surface.

### **An Opportunity for Radio Dealers**

Condensite Celoron Radio Panels and Parts offer a clean cut opportunity to the dealer who is keen on building business on a quality basis. Write us to-day. Let us send you the facts. You'll be interested.

## **Diamond State Fibre Company**

**Bridgeport (near Philadelphia), Pa.**

**Branch Factory and Warehouse, Chicago.**

*Offices in principal cities*

**In Canada: Diamond State Fibre Co., Ltd., Toronto.**

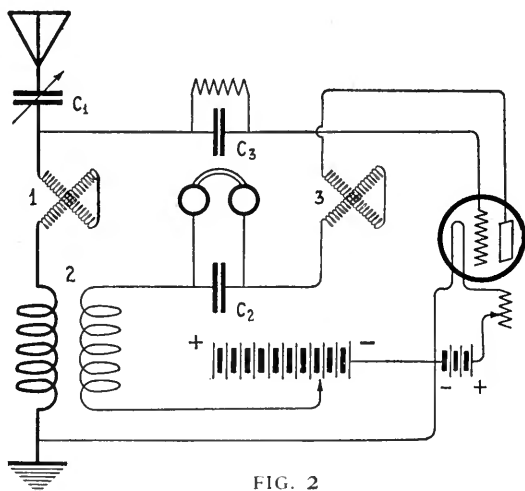

FIG. 2

Several other minor changes have been made. The variable condenser has been shifted to the antenna side of the coupler primary, by which maneuver, control of the set is apparently facilitated, owing to a possible stabilizing effect of the ground on the directly coupled grid. A grid leak, quite an important item, has been added, and a condenser placed across the phones or primary of the first transformer, as the case may be. For convenience, the receivers have been shifted nearer to the plate. If, when constructing the set, the experimenter does not fancy the immediate expense of amplifiers, the auxiliary apparatus is merely eliminated on the diagram, along with the extra B batteries, and the phones connected in place of the first jack.

A slight variation in the fundamental circuit, which has proved remarkably popular where introduced, is shown in Fig. 2. The tuning elements, exclusive of the variable condenser, are three home-made variometers, which may be constructed for less than fifty cents apiece. The variometers are wound on cardboard stators and rotors (the stationary and revolving parts) three and a half inches in diameter respectively. The stators are wound with 18 turns of No. 22 or No. 24 single cotton-covered wire, and the rotors with 22 turns of the same. The variometers may be panel mounted by bushings as described in the *Grid* in Radio Broadcast for December. The connection between the stator and rotor of variometer number two is broken in order to permit the hooking-in of the detector "B" battery. C2 is a .0015 mfd. telephone shunt condenser.

The set is slightly more difficult to tune than Mr. Parker's circuit, but the semi-regenerative function of the third variometer is soon comprehended with surprising results. Variometer number one, in conjunction with the variable condenser (which should be provided with a shorting device for waves in the neighborhood of six hundred meters) varies the wavelength. The middle variometer controls feedback or regeneration.

*The set has no taps*, all tuning elements being *continuously variable* by the variometers and condenser. As a result, it is remarkably selective, with tuning possibilities that, used appreciatively, rival the best inductively coupled outfits.

SUPPLEMENTAL LIST OF BROADCASTING STATIONS IN THE UNITED STATES FROM NOVEMBER 23  
TO DECEMBER 24 INCLUSIVE

CALL SIGNAL	OPERATED AND CONTROLLED BY	LOCATION
KFCL	Los Angeles Union Stock Yards	Los Angeles, Calif.
KFCQ	Motor Service Station	Casper, Wyoming
KFDB	Mercantile Trust Company of California	San Francisco, Calif.
KFDC	Radio Supply Co.	Spokane, Wash.
KDFD	Wyoming Radio Corp.	Casper, Wyoming
KFDH	University of Arizona	Tucson, Arizona
KFDJ	Oregon Agricultural College	Corvallis, Oregon
KFDL	Knight-Campbell Music Co.	Denver, Colorado
KFEJ	Guy Greason	Tacoma, Washington
KFEP	Radio Equipment Co.	Denver, Colorado
KFGG	Astoria <i>Budget</i>	Astoria, Oregon
KFGH	Leland Stanford Jr. Univ.	Stanford University, Calif.
KFHJ	Fallon Company	Santa Barbara, Calif.
KGW	Portland <i>Oregonian</i>	Portland, Oregon
WLAG	Cutting & Washington Radio Corporation	Minneapolis, Minn.



No Wireless  
Receiving  
set is  
complete  
without

**MAGNAVOX**  
Radio  
*The Reproducer Supreme*



**R-2 Magnavox Radio** with 18-inch horn: this instrument is intended for those who wish the utmost in amplifying power; for large audiences, dance halls, etc. . . . . \$85.00

**R-3 Magnavox Radio** with 14-inch horn: the ideal instrument for use in homes, offices, amateur stations, etc. . . . . \$45.00

**Model C Magnavox Power Amplifier** insures getting the largest possible power input for your Magnavox Radio. 2 Stage . \$80.00  
3 Stage . 110.00

When you purchase a Magnavox product you possess an instrument of the highest quality and service.

*Magnavox products can be had of good dealers everywhere. Write us for copy of new illustrated booklet.*

EVERY improvement in the science of radio broadcasting and reception only emphasizes the truly extraordinary qualities of Magnavox.

To enjoy all that radio offers in the way of daily concert, lecture and news, ask your dealer for a receiving set equipped with the Magnavox Radio Reproducer and 2-stage Power Amplifier.

Magnavox can be used with any good receiving set—the better the set, the more Magnavox can do for you.

**The Magnavox Co., Oakland, California**  
New York: 370 Seventh Avenue

WOAH	Palmetto Radio Corp.	Charleston, S. C.
WOAK	Collins Hardware Co.	Frankfort, Ky.
WOAL	William E. Woods	Webster Grove, Mo.
WOAN	James D. Vaughan	Lawrenceburg, Tenn.
WOAP	Kalamazoo College	Kalamazoo, Michigan
WOAQ	Portsmouth Radio Ass'n.	Portsmouth, Va.
WOAR	Henry P. Lundskow	Kenosha, Wisconsin
WOAS	Bailey's Radio Shop	Middletown, Conn.
WOAT	Boyd Martell Hamp	Wilmington, Delaware
WOAU	Sowder Bolling Piano Company	Evansville, Indiana
WOAW	Woodmen of the World	Omaha, Nebraska
WOAX	Franklyn J. Wolff	Trenton, New Jersey
WOAY	John M. Wilder	Birmingham, Ala.
WOAZ	Penick Hughes Co.	Stanford, Texas
WPAC	Donaldson Radio Co.	Okmulgee, Okla.
WPAG	Central Radio Co., Inc.	Independence, Mo.
WPAH	Wisconsin Dept. of Markets	Waupaca, Wisconsin
WPAJ	Doolittle Radio Corporation	New Haven, Conn.
WPAK	North Dakota Agricultural College	North Dakota
WPAP	Theodore S. Phillips	Winchester, Ky.
WPAQ	General Sales & Engr. Co.	Frostburg, Md.
WPAR	R. A. Ward	Beloit, Kansas
WPAT	Saint Patrick's Cathedral	El Paso, Texas
WPAU	Concordia College	Moorhead, Minn.
WQAB	Southwest Missouri State Teachers' College	Springfield, Mo.
WQAK	Appel-Higley Electric Co.	Dubuque, Iowa
WQAL	Cole County Tel. & Tel. Co.	Mattoon, Ill.
WRAA	Rice Institute	Houston, Texas
WRAN	Black Hawk Electric Company	Waterloo, Iowa
WSAJ	Grove City College	Grove City, Pa.
WTAC	Penn Traffic Co.	Johnstown, Pa.
WTAU	Ruegy Battery & Elect. Co.	Tecumseh, Neb.
WWAD	Wright & Wright, Inc	Philadelphia, Pa.

## The Grid

### QUESTIONS AND ANSWERS

The Grid is a Question and Answer Department maintained especially for the radio amateurs. Full answers will be given wherever possible. In answering questions, those of a like nature will be grouped together and answered by one article. Every effort will be made to keep the answers simple and direct, yet fully self-explanatory. Questions should be addressed to Editor, "The Grid," Radio Broadcast, Garden City, N. Y. The letter containing the questions should have the full name and address of the writer and also his station call letter, if he has one. Names, however, will not be published.

#### LOOSE COUPLERS

*How does a loose coupler work without any connection between the primary and secondary?*

*I have a set consisting of a loose coupler, variable condenser, crystal detector, fixed condenser and Turney 3000-ohm phones. I get no results at all. Could you help locate my trouble? My antenna is of the T type; one end is about fifty feet high and the other end sixty feet high.*

*I enclose my hookup.*

—J. B., NEW YORK CITY.

**I**N a general way, electricity is transferred from the primary of a loose coupler to the secondary by means of a phenomenon called induction. Whenever electricity traverses a circuit, such as from the antenna, through the coupler primary to the ground, magnetic

lines of force, similar to those surrounding the poles of a horseshoe magnet, spread out from the conductor, and reproduce magnetically every fluctuation of the current. When these lines of force cut an adjacent conductor, such as the secondary of the coupler, they "generate" another current which exactly follows the variations of the magnetic field, and therefore duplicates, excepting in strength (there is a small loss) the antenna current. Large generators in power houses operate on this principle, and are nothing more than machines which pass a dense flux, at a high speed, through windings from which the current is drawn.

However, in a loose coupler, induction alone does not explain the transference of energy from primary to secondary, for it is doubtful that with the low inductance (due to the few turns of wire and the absence of an iron core), and the comparatively great distance that often separates the

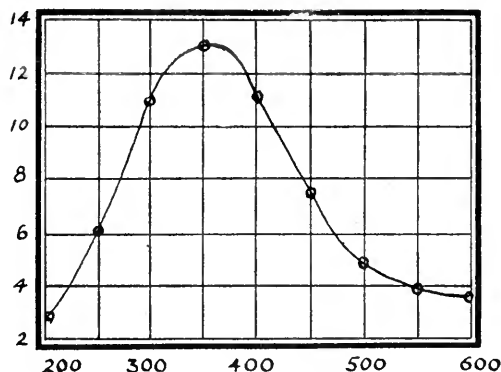

CHART I

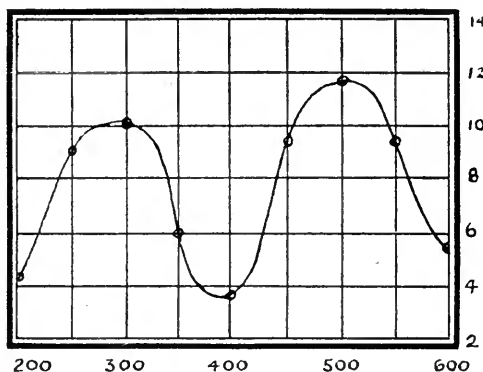

CHART II

# The Importance of Uniformity

*How to avoid amplification losses when using radio frequency*

**B**EFORE you purchase a radio frequency transformer be sure to find this out. Does it show marked depressions and peaks in the amplification range between 250 and 500 meters? No amplification is possible in such depressions. Getting distant stations becomes a gamble as to whether or not there is any amplification at a given point.

### How to get uniformity

**T**HERE is a radio frequency amplifying transformer which has been so perfected that the peaks and depressions are eliminated. This is the Acme R-2. This unique transformer, after long months of experimentation, has been perfected with a special type of iron core and windings which eliminate the peaks and depressions and provide a steadily increasing volume of amplification up to the point of maximum importance—360 meters.

### Gets greater distance

**E**QUALLY important is the far greater distances you get broadcasting. The Acme R-2 used in a radio frequency amplifier builds up wave energy before passing it on to the detector. You hear signals or-

dinarly inaudible. The simplest and most elementary type of set, either vacuum tube or crystal receiver type, will have its range tremendously increased.

### The best method

**T**O SECURE maximum results use three stages of Acme Radio Frequency Amplification (R-2, R-3 and R-4), a crystal detector and three stages of Acme Audio Frequency Amplification. This insures maximum sensitivity and intensity, quietness in operation and freedom from distortion. A small indoor antenna or loop may be used and sufficient intensity obtained to operate the Acme Kleerspeaker, providing perfect entertainment for a roomful of people.

You can get these and other Acme Products at radio, electrical and many hardware stores.

Write for booklet R-2 showing proper hook-ups and other information.



Acme R-2 Radio Frequency Amplifying Transformer. Price \$5. (East of Rocky Mountains.)

## The Acme Apparatus Company

*(Pioneer transformer and radio engineers and manufacturers.)*

CAMBRIDGE, MASS., U. S. A.

New York, . . . . . 1270 Broadway  
Chicago, . . . . . 184 W. Washington Street

# ACME ~ for amplification

windings, that more than a small fraction of the received signal is transferred to the detecting circuit in this manner. It is probable that the primary, acting as a transmitting antenna energized by the received signal, wirelesses the

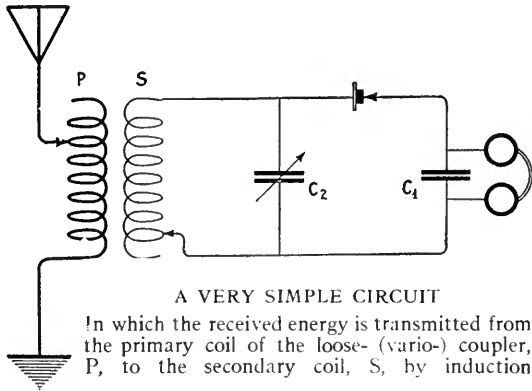

energy to the secondary which is virtually a receiving aerial, and which must be tuned to pick it up!

The advantages of the loose coupler over the single circuit tuner are several. Aside from permitting delicate and sharp tuning by slight changes in the coupling, which simultaneously varies the wavelengths of the primary and secondary, the coupler is very efficient in eliminating undesired signals, a quality known as selectivity. If the primary is tuned to a certain station, the antenna will pick up its wave with a partial exclusion of all others. But at the same time, signals from a powerful or near-by transmitter, tuned to a different wave, will force oscillations in the non-resonant circuit. The secondary, which must be tuned to the same wave as the primary, will readily receive energy induced by the tuned station, but will discriminate against, and still further tend to eliminate, the forced signal. The primary and secondary are analogous to two water filters. While some impurities may flow past the first, few if any pass the second.

#### HUNTING TROUBLE ON A CRYSTAL RECEIVER

**T**HOUGH your antenna is not all that could be desired (we suggest a single wire inverted L, from a hundred to a hundred and fifty feet long), you should certainly receive signals on your set, which is probably the most efficient combination of instruments for crystal reception. One or more of several things may be at fault.

The condensers  $C_1$  and  $C_2$  should first be removed from the circuit, one at a time in the order named, and the set tuned after each removal. If signals are received, it is evident that one or both of the condensers is shorted. When the variable capacity is at fault, the experimenter can probably repair it by adjusting the relative position of

the stationary and revolving plates. If it is the fixed condenser that is shorted, it is best replaced by a new one. The receivers should be next tested by touching the ends of the phone cord to the terminals of a dry cell. If the headset is in good condition, a loud definite click will be heard. Having once determined that the receivers are not at fault, the phones themselves may be used for further testing the set.

It is possible that the antenna is grounded and this should be next ascertained by disconnecting the aerial from the coupler and transferring it to one of the receiver cords. The remaining phone cord is grounded through a dry battery. On making and breaking the connection, a fairly loud click will indicate the difficulty.

The primary and secondary are next in order, and are individually tested by connecting the phones to one end of the winding, and the other to the switch lever through the dry cell. As the circuit is interrupted by running the lever on and off each tap, a loud click should be heard in the phones.

The connections between the various instruments, particularly soldered joints, should be carefully examined. Inexperienced enthusiasts often use rosin as a poor substitute for soldering pastes. Aside from being an unsatisfactory flux, if the iron is slightly cool it will remain between the metals, merely sticking the solder on with a highly insulative glue, with the result that an ostensibly perfectly soldered joint is no connection at all! After having determined that the condensers are not broken down or shorted, a battery substituted for the crystal detector will indicate, by a definite click, that the essential secondary connections are well wired.

The last possibility is that the detector crystal may not be a sensitive one, a condition that should be ascertained by

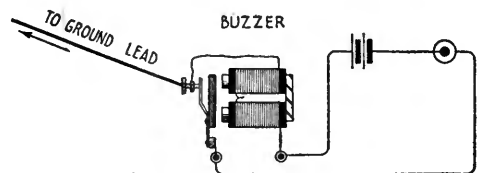

#### HOW TO CONNECT A BUZZER

For use in testing your crystal set

buzzer test, an arrangement that is at any time a desirable addition to a crystal set. A small, high-toned radio buzzer should be connected as here shown, where the only deviation from the conventional announcing buzzer hook-up is the single wire running from the stationary contact to the ground lead on the receiver. If the push-button is replaced by a telegraph key, the buzzer may be used for code practice. The detector is adjusted while the buzzer is vibrating, and the note will be plainly audible in the receivers when the cat-whisker is on a sensitive spot.

## What Would You Like to Have in Radio Broadcast?

The editors would be pleased to hear from readers of the magazine on the following (or other) topics:

1. The kind of article, or diagram, or explanation, or improvement you would like to see in RADIO BROADCAST.

2. What has interested you most, and what least, in the numbers you have read so far.